



Complete, Quad, 12-/14-/16-Bit, Serial Input, Unipolar/Bipolar Voltage Output DACs

Preliminary Technical Data

AD5724/AD5734/AD5754

FEATURES

- Complete, quad, 12-/14-/16-bit D/A converter
- Operates from single/dual supplies
- Software programmable output range
 - +5 V, +10 V, +10.8 V, ±5 V, ±10 V, ±10.8 V
- INL error: ±16 LSB maximum, DNL error: ±1 LSB maximum
- Total unadjusted error (TUE): 0.1% FSR maximum
- Settling time: 10 μs maximum
- Integrated reference buffers
- Output control during power-up/brownout
- Simultaneous updating via $\overline{\text{LDAC}}$
- Asynchronous $\overline{\text{CLR}}$ to zero-/mid-scale
- DSP-/microcontroller-compatible serial interface
- 24-lead TSSOP
- Operating temperature range: -40°C to +85°C
- iCMOS™ process technology¹

APPLICATIONS

- Industrial automation
- Closed-loop servo control, process control
- Automotive test and measurement
- Programmable logic controllers

GENERAL DESCRIPTION

The AD5724/AD5734/AD5754 are quad, 12-/14-/16-bit serial input, voltage output, digital-to-analog converters. They operate from single supply voltages of +4.5 V up to +16.5 V or dual supply voltages from ±4.5 V up to ±16.5 V. Nominal full-scale output range is software-selectable from the options of +5 V, +10 V, +10.8 V, ±5 V, ±10 V, or ±10.8 V. Integrated output amplifiers, reference buffers, and proprietary power-up/power-down control circuitry are also provided.

The parts offer guaranteed monotonicity, integral nonlinearity (INL) of ±16 LSB maximum, low noise, and 10 μs maximum settling time.

The AD5724/AD5734/AD5754 use a serial interface that operates at clock rates up to 30 MHz and are compatible with DSP and microcontroller interface standards. Double buffering allows the simultaneous updating of all DACs. The input coding is user-selectable twos complement or offset binary for a bipolar output (depending on the state of pin BIN/2sComp), and straight binary for a unipolar output. The asynchronous clear function clears all DAC registers to a user-selectable zero-scale or mid-scale output. The parts are available in a 24-lead TSSOP and offer guaranteed specifications over the -40°C to +85°C industrial temperature range.

Table 1. Pin Compatible Devices

| Part Number | Description |
|-------------------------|---|
| AD5724R/AD5734R/AD5754R | AD5724/AD5734/AD5754 with internal reference. |
| AD5722/AD5732/AD5752 | Complete, dual, 12-/14-/16-bit, serial input, unipolar/bipolar, voltage output DAC. |
| AD5722R/AD5732R/AD5752R | AD5722/AD5732/AD5752 with internal reference. |

¹ For analog systems designers within industrial/instrumentation equipment OEMs who need high performance ICs at higher-voltage levels, iCMOS is a technology platform that enables the development of analog ICs capable of 30 V and operating at ±15 V supplies while allowing dramatic reductions in power consumption and package size, and increased AC and DC performance.

Rev. C

Information furnished by Analog Devices is believed to be accurate and reliable. However, no responsibility is assumed by Analog Devices for its use, nor for any infringements of patents or other rights of third parties that may result from its use. Specifications subject to change without notice. No license is granted by implication or otherwise under any patent or patent rights of Analog Devices. Trademarks and registered trademarks are the property of their respective owners.

TABLE OF CONTENTS

| | | | |
|--|----|--|----|
| Features | 1 | Configuring the AD5724/AD5734/AD5754 | 22 |
| Applications | 1 | Transfer Function | 22 |
| General Description | 1 | Input Register | 26 |
| Functional Block Diagram | 3 | Data Register | 26 |
| Specifications | 4 | Output Range Select Register | 27 |
| Dual supply specifications | 4 | Control Register | 27 |
| Single Supply Specifications | 6 | Power Control Register | 28 |
| AC Performance Characteristics | 7 | Features | 29 |
| Timing Characteristics | 8 | Analog Output Control | 29 |
| Absolute Maximum Ratings | 11 | Overcurrent Protection | 29 |
| ESD Caution | 11 | Thermal Shutdown | 29 |
| Pin Configuration and Function Descriptions | 12 | Applications Information | 30 |
| Typical Performance Characteristics | 13 | +5V / ±5V operation | 30 |
| Terminology | 18 | Layout Guidelines | 30 |
| Theory of Operation | 20 | Galvanically Isolated Interface | 30 |
| Architecture | 20 | Voltage Reference Selection | 30 |
| Serial Interface | 20 | Microprocessor Interfacing | 31 |
| Load DAC ($\overline{\text{LDAC}}$) | 22 | Outline Dimensions | 32 |
| Asynchronous Clear ($\overline{\text{CLR}}$) | 22 | Ordering Guide | 32 |

REVISION HISTORY

PrC – Preliminary Revision, November 16, 2007

FUNCTIONAL BLOCK DIAGRAM

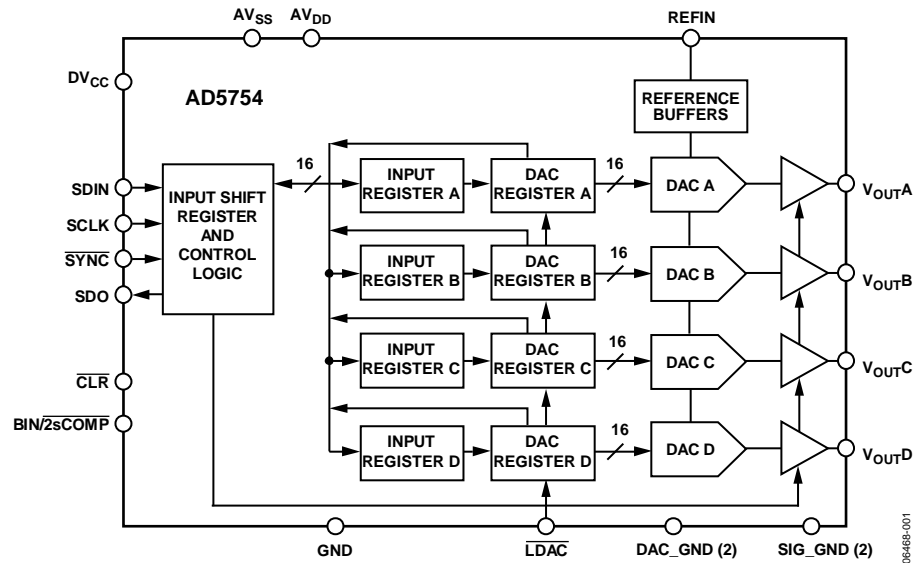

Figure 1.

0646B-001

SPECIFICATIONS

DUAL SUPPLY SPECIFICATIONS

$AV_{DD} = 4.5\text{ V}^1$ to 16.5 V , $AV_{SS} = -4.5\text{ V}^1$ to -16.5 V , $GND = 0\text{ V}$, $REFIN = +2.5\text{ V}$, $DV_{CC} = 2.7\text{ V}$ to 5.5 V ,
 $R_{LOAD} = 2\text{ k}\Omega$, $C_{LOAD} = 200\text{ pF}$; all specifications T_{MIN} to T_{MAX} , $\pm 10\text{ V}$ range unless otherwise noted.

Table 2.

| Parameter | Value | Unit | Test Conditions/Comments |
|---|------------------------|----------------------------------|--|
| ACCURACY | | | Outputs unloaded |
| Bipolar Output | | | |
| Resolution | | | |
| AD5754 | 16 | Bits | |
| AD5734 | 14 | Bits | |
| AD5724 | 12 | Bits | |
| Total Unadjusted Error (TUE) | 0.1 | % FSR max | Over temperature, supplies, and time |
| Relative Accuracy (INL) | | | |
| B Grade | ± 16 | LSB max | @ 16-bit resolution |
| Differential Nonlinearity (DNL) | ± 1 | LSB max | Guaranteed monotonic (@ 16-bit resolution) |
| Bipolar Zero Error | ± 5 | mV max | @ 25°C, error at other temperatures obtained using Bipolar Zero TC |
| Bipolar Zero TC ² | ± 8 | ppm FSR/°C max | |
| Zero-Scale Error | ± 1 | mV max | @ 25°C, error at other temperatures obtained using Zero-Scale TC |
| Zero-Scale TC ² | ± 8 | ppm FSR/°C max | |
| Gain Error | ± 0.05 | % FSR max | @ 25°C, error at other temperatures obtained using Gain TC |
| Gain TC ² | ± 8 | ppm FSR/°C max | |
| DC Crosstalk ² | 0.6 | LSB max | @ 16-bit resolution $AV_{SS} = 0\text{ V}$ |
| Unipolar Output | | | |
| Resolution | | | |
| AD5754 | 16 | Bits | |
| AD5734 | 14 | Bits | |
| AD5724 | 12 | Bits | |
| Total Unadjusted Error (TUE) | 0.1 | % FSR max | Over temperature, supplies, and time |
| Relative Accuracy (INL) | | | |
| B Grade | ± 16 | LSB max | @ 16-bit resolution |
| Differential Nonlinearity (DNL) | ± 1 | LSB max | Guaranteed monotonic (@ 16 bit-resolution) |
| Zero-Scale Error | +10 | mV max | @ 25°C, error at other temperatures obtained using Zero-Scale TC |
| Zero-Scale TC ² | ± 4 | ppm FSR/°C max | |
| Offset Error | ± 10 | mV max | |
| Gain Error | ± 0.05 | % FSR max | @ 25°C, error at other temperatures obtained using Gain TC |
| Gain TC ² | ± 4 | ppm FSR/°C max | |
| DC Crosstalk ² | 0.6 | LSB max | @ 16-bit resolution |
| REFERENCE INPUT² | | | |
| Reference Input Voltage | 2.5 | V nom | $\pm 1\%$ for specified performance |
| DC Input Impedance | 1 | M Ω min | Typically 100 M Ω |
| Input Current | ± 10 | μA max | Typically $\pm 30\text{ nA}$ |
| Reference Range | 2 to 3 | V min to V max | |
| OUTPUT CHARACTERISTICS² | | | |
| Output Voltage Range | ± 10.8 ± 12 | V min to V max V min to V max | $AV_{DD}/AV_{SS} = \pm 11.7\text{ V min}$, $REFIN = +2.5\text{ V}$ $AV_{DD}/AV_{SS} = \pm 12.9\text{ V min}$, $REFIN = +3\text{ V}$ |

| Parameter | Value | Unit | Test Conditions/Comments |
|--|------------------------|---------------------|---|
| Headroom | 0.9 | V max | For specified performance |
| | 0.5 | V typ | |
| Output Voltage TC | ±8 | ppm FSR/°C max | |
| Output Voltage Drift vs. Time | ±12 | ppm FSR/500 hr typ | |
| | ±15 | ppm FSR/1000 hr typ | |
| Short-Circuit Current | 20 | mA typ | |
| Load | 2 | kΩ min | |
| Capacitive Load Stability | 4000 | pF max | |
| DC Output Impedance | 0.5 | Ω typ | |
| DIGITAL INPUTS² | | | DV _{CC} = 2.7 V to 5.5 V, JEDEC compliant |
| V _{IH} , Input High Voltage | 2 | V min | Per pin Per pin |
| V _{IL} , Input Low Voltage | 0.8 | V max | |
| Input Current | ±1 | μA max | |
| Pin Capacitance | 5 | pF typ | |
| DIGITAL OUTPUTS (SDO)² | | | |
| V _{OL} , Output Low Voltage | 0.4 | V max | DV _{CC} = 5 V ± 10%, sinking 200 μA |
| V _{OH} , Output High Voltage | DV _{CC} - 1 | V min | DV _{CC} = 5 V ± 10%, sourcing 200 μA |
| V _{OL} , Output Low Voltage | 0.4 | V max | DV _{CC} = 2.7 V to 3.6 V, sinking 200 μA |
| V _{OH} , Output High Voltage | DV _{CC} - 0.5 | V min | DV _{CC} = 2.7 V to 3.6 V, sourcing 200 μA |
| High Impedance Leakage Current | ±1 | μA max | |
| High Impedance Output Capacitance | 5 | pF typ | |
| POWER REQUIREMENTS | | | |
| AV _{DD} | 4.5 to 16.5 | V min to V max | Outputs unloaded Outputs unloaded V _{IH} = DV _{CC} , V _{IL} = GND, 0.5 μA typ ±12 V operation, outputs unloaded |
| AV _{SS} | -4.5 to -16.5 | V min to V max | |
| DV _{CC} | 2.7 to 5.5 | V min to V max | |
| Power Supply Sensitivity ² | | | |
| ΔV _{OUT} /ΔAV _{DD} | -75 | dB typ | |
| AI _{DD} | 2 | mA/channel max | |
| AI _{SS} | 1.5 | mA/channel max | |
| DI _{CC} | 1 | μA max | |
| Power Dissipation | TBD | mW typ | |
| Power-Down Currents | | | |
| AI _{DD} | 80 | μA typ | |
| AI _{SS} | TBD | μA typ | |
| DI _{CC} | TBD | μA typ | |

¹ For specified performance minimum headroom requirement is 0.9V

² Guaranteed by characterization. Not production tested.

SINGLE SUPPLY SPECIFICATIONS

$AV_{DD} = 4.5\text{ V}^1$ to 16.5 V , $AV_{SS} = 0\text{ V}$, $GND = 0\text{ V}$, $REFIN = 2.5\text{ V}$, $DV_{CC} = 2.7\text{ V}$ to 5.5 V ,
 $R_{LOAD} = 2\text{ k}\Omega$, $C_{LOAD} = 200\text{ pF}$; all specifications T_{MIN} to T_{MAX} , 10 V range unless otherwise noted.

Table 3.

| Parameter | Value | Unit | Test Conditions/Comments |
|---|-----------------|-------------------|---|
| ACCURACY | | | |
| Resolution | | | Outputs unloaded |
| AD5754 | 16 | Bits | |
| AD5734 | 14 | Bits | |
| AD5724 | 12 | Bits | |
| Total Unadjusted Error (TUE) | 0.1 | % FSR max | Across temperature and supplies |
| Relative Accuracy (INL) | | | |
| B Grade | ± 16 | LSB max | @ 16-bit resolution |
| Differential Nonlinearity (DNL) | ± 1 | LSB max | Guaranteed monotonic (@ 16-bit resolution) |
| Zero-Scale Error | +10 | mV max | @ 25°C, error at other temperatures obtained using Zero-Scale TC |
| Zero-Scale TC ² | ± 4 | ppm FSR/°C max | |
| Offset Error | ± 10 | mV max | |
| Gain Error | ± 0.02 | % FSR max | @ 25°C, error at other temperatures obtained using Gain TC |
| Gain TC ² | ± 8 | ppm FSR/°C max | |
| DC Crosstalk ² | 0.6 | LSB max | @ 16-bit resolution |
| REFERENCE INPUT² | | | |
| Reference Input Voltage | 2.5 | V nom | $\pm 1\%$ for specified performance |
| DC Input Impedance | 1 | M Ω min | Typically 100 M Ω |
| Input Current | ± 10 | μA max | Typically $\pm 30\text{ nA}$ |
| Reference Range | 2 to 3 | V min to V max | |
| OUTPUT CHARACTERISTICS² | | | |
| Output Voltage Range | 10.8 | V max | $AV_{DD} = 11.7\text{ V}$ min, $REFIN = 2.5\text{ V}$ |
| | 12 | V max | $AV_{DD} = 12.9\text{ V}$ min, $REFIN = 3.75\text{ V}$ |
| Headroom | 0.9 | V max | |
| | 0.5 | V typ | |
| Output Voltage TC | ± 8 | ppm FSR/°C max | |
| Output Voltage Drift vs. Time | ± 12 | ppm/500 hr typ | |
| | ± 15 | ppm/1000 hr typ | |
| Short Circuit Current | 20 | mA typ | |
| Load | 2 | k Ω max | For specified performance |
| Capacitive Load Stability | 4000 | pF max | |
| DC Output Impedance | 0.5 | Ω typ | |
| DIGITAL INPUTS² | | | |
| V_{IH} , Input High Voltage | 2 | V min | $DV_{CC} = 2.7\text{ V}$ to 5.5 V , JEDEC compliant |
| V_{IL} , Input Low Voltage | 0.8 | V max | |
| Input Current | ± 1 | μA max | Per pin |
| Pin Capacitance | 5 | pF max | Per pin |
| DIGITAL OUTPUTS (SDO)² | | | |
| V_{OL} , Output Low Voltage | 0.4 | V max | $DV_{CC} = 5\text{ V} \pm 10\%$, sinking 200 μA |
| V_{OH} , Output High Voltage | $DV_{CC} - 1$ | V min | $DV_{CC} = 5\text{ V} \pm 10\%$, sourcing 200 μA |
| V_{OL} , Output Low Voltage | 0.4 | V max | $DV_{CC} = 2.7\text{ V}$ to 3.6 V , sinking 200 μA |
| V_{OH} , Output High Voltage | $DV_{CC} - 0.5$ | V min | $DV_{CC} = 2.7\text{ V}$ to 3.6 V , sourcing 200 μA |
| High Impedance Leakage Current | ± 1 | μA max | |
| High Impedance Output Capacitance | 5 | pF typ | |
| POWER REQUIREMENTS | | | |
| AV_{DD} | 4.5 to 16.5 | V min to V max | |
| DV_{CC} | 2.7 to 5.5 | V min to V max | |

| Parameter | Value | Unit | Test Conditions/Comments |
|---|-------|----------------|---|
| Power Supply Sensitivity ² $\Delta V_{OUT}/\Delta V_{DD}$ | -75 | dB typ | Outputs unloaded $V_{IH} = DV_{CC}$, $V_{IL} = GND$, 0.5 μA typ 12 V operation, outputs unloaded |
| I_{DD} | 2.75 | mA/channel max | |
| I_{LCC} | 1 | μA max | |
| Power Dissipation | TBD | mW typ | |
| Power-Down Currents | | | |
| I_{DD} | 80 | μA typ | |
| I_{LCC} | TBD | μA typ | |

¹ For specified performance minimum headroom requirement is 0.9V

² Guaranteed by characterization. Not production tested.

AC PERFORMANCE CHARACTERISTICS

$AV_{DD} = 4.5 V^1$ to 16.5 V, $AV_{SS} = -4.5 V^1$ to -16.5 V / 0V, $GND = 0 V$, $REFIN = 2.5 V$, $DV_{CC} = 2.7 V$ to 5.5 V

$R_{LOAD} = 2 k\Omega$, $C_{LOAD} = 200 pF$; all specifications T_{MIN} to T_{MAX} , $\pm 10 V$ range unless otherwise noted.

Table 4.

| Parameter ² | B Grade | Unit | Test Conditions/Comments |
|--|---------|---------------------|--|
| DYNAMIC PERFORMANCE | | | |
| Output Voltage Settling Time | 8 | μs typ | Full-scale step (20 V) to $\pm 0.03\%$ FSR |
| | 10 | μs max | |
| | 5 | μs max | |
| Slew Rate | 4.5 | V/ μs typ | 512 LSB step settling (@ 16 bits) |
| Digital-to-Analog Glitch Energy | 35 | nV-sec typ | |
| Glitch Impulse Peak Amplitude | 25 | mV typ | |
| Digital Crosstalk | 10 | nV-sec typ | |
| DAC-to-DAC Crosstalk | 10 | nV-sec typ | |
| Digital Feedthrough | 0.1 | nV-sec typ | |
| Output Noise (0.1 Hz to 10 Hz Bandwidth) | 0.05 | LSB p-p typ | |
| Output Noise (100 kHz Bandwidth) | 80 | μV rms max | |
| 1/f Corner Frequency | 1 | kHz typ | |
| Output Noise Spectral Density | 120 | nV/ \sqrt{Hz} typ | |

¹ For specified performance minimum headroom requirement is 0.8V

² Guaranteed by design and characterization, not production tested.

TIMING CHARACTERISTICS

$AV_{DD} = 4.5\text{ V to }16.5\text{ V}$, $AV_{SS} = -4.5\text{ V to }-16.5\text{ V} / 0\text{V}$, $GND = 0\text{ V}$, $REFIN = 2.5\text{ V}$, $DV_{CC} = 2.7\text{ V to }5.5\text{ V}$
 $R_{LOAD} = 2\text{ k}\Omega$, $C_{LOAD} = 200\text{ pF}$; all specifications T_{MIN} to T_{MAX} , unless otherwise noted.

Table 5.

| Parameter ^{1, 2, 3} | Limit at T_{MIN} , T_{MAX} | Unit | Description |
|------------------------------|--------------------------------|-------------------|---|
| t_1 | 33 | ns min | SCLK cycle time |
| t_2 | 13 | ns min | SCLK high time |
| t_3 | 13 | ns min | SCLK low time |
| t_4 | 13 | ns min | \overline{SYNC} falling edge to SCLK falling edge setup time |
| t_5 | 13 | ns min | SCLK falling edge to \overline{SYNC} rising edge |
| t_6 | 100 | ns min | Minimum \overline{SYNC} high time (write mode) |
| t_7 | 5 | ns min | Data setup time |
| t_8 | 0 | ns min | Data hold time |
| t_9 | 20 | ns min | \overline{LDAC} falling edge to \overline{SYNC} falling edge |
| t_{10} | 20 | ns min | \overline{SYNC} rising edge to \overline{LDAC} falling edge |
| t_{11} | 20 | ns min | \overline{LDAC} pulse width low |
| t_{12} | 1.5 | $\mu\text{s max}$ | \overline{LDAC} falling edge to DAC output response time |
| t_{13} | 10 | $\mu\text{s max}$ | DAC output settling time |
| t_{14} | 1.5 | ns max | \overline{SYNC} rising edge to output response time ($\overline{LDAC} = 0$) |
| t_{15} | 20 | ns min | \overline{CLR} pulse width low |
| t_{16} | 2.5 | $\mu\text{s max}$ | \overline{CLR} pulse activation time |
| t_{17}^4 | 13 | ns min | \overline{SYNC} rising edge to SCLK rising edge |
| t_{18}^4 | 40 | ns max | SCLK rising edge to SDO valid ($C_{LSDO}^5 = 15\text{ pF}$) |
| t_{19} | 200 | ns min | Minimum \overline{SYNC} high time (readback/daisy-chain mode) |

¹ Guaranteed by characterization. Not production tested.

² All input signals are specified with $t_r = t_f = 5\text{ ns}$ (10% to 90% of DV_{CC}) and timed from a voltage level of 1.2 V.

³ See Figure 2, Figure 3, and Figure 4.

⁴ Daisy-chain and Readback mode.

⁵ C_{LSDO} = Capacitive load on SDO output.

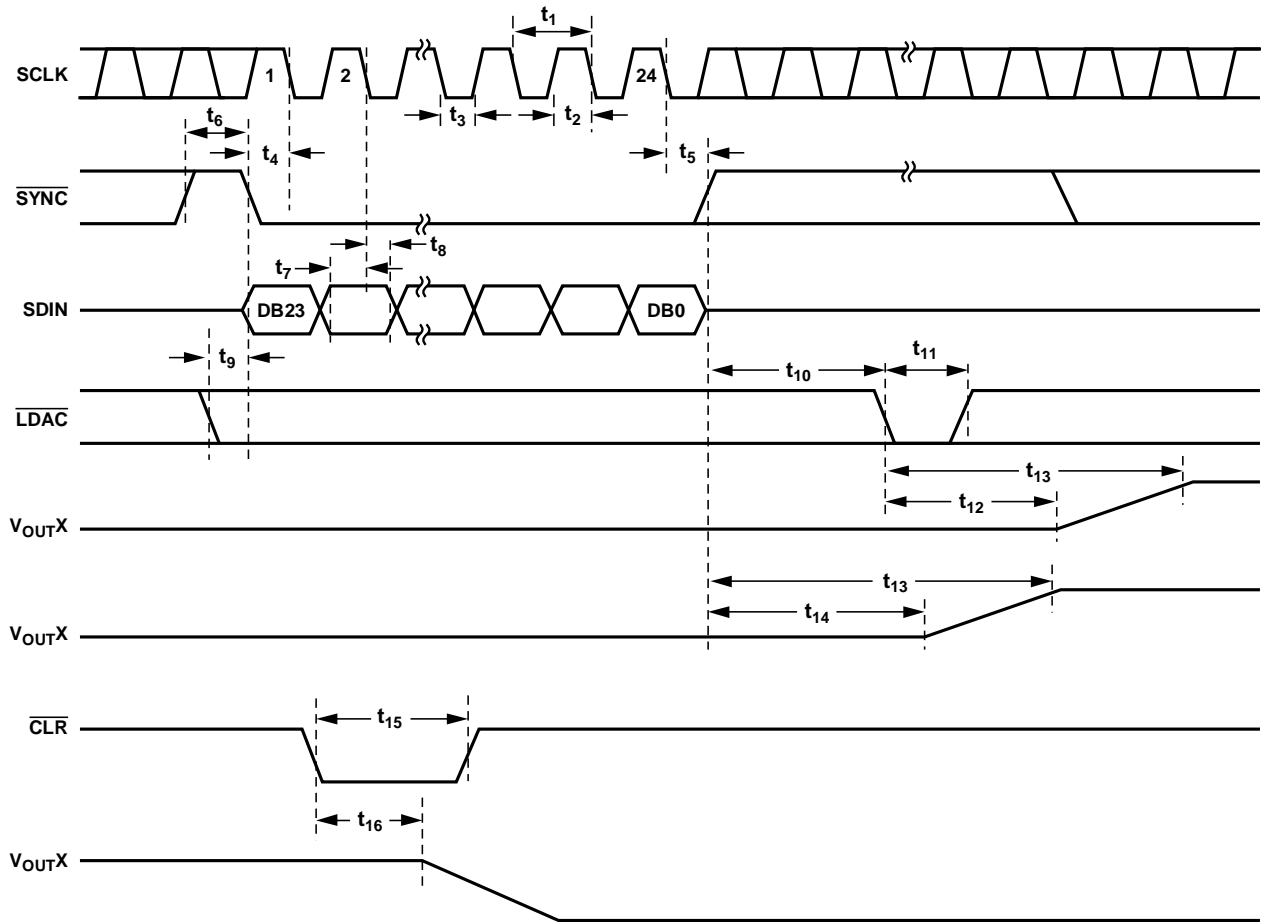

Figure 2. Serial Interface Timing Diagram

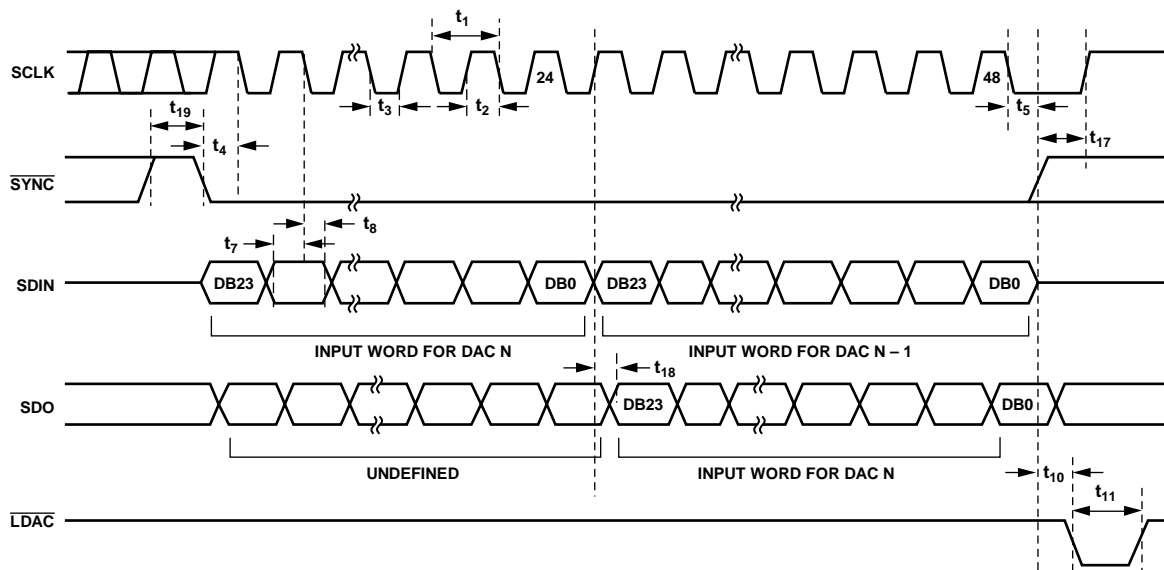

Figure 3. Daisy Chain Timing Diagram

06468-003

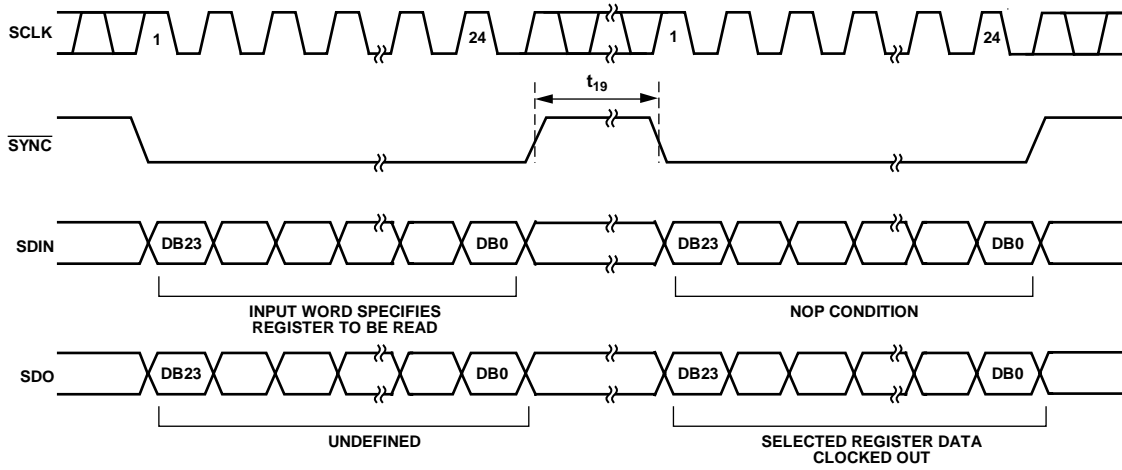

Figure 4. Readback Timing Diagram

ABSOLUTE MAXIMUM RATINGS

$T_A = 25^\circ\text{C}$ unless otherwise noted.

Transient currents of up to 100 mA do not cause SCR latch-up.

Table 6.

| Parameter | Rating |
|---|---|
| AV_{DD} to GND | -0.3 V to +17 V |
| AV_{SS} to GND | +0.3 V to -17 V |
| DV_{CC} to GND | -0.3 V to +7 V |
| Digital Inputs to GND | -0.3 V to $DV_{CC} + 0.3$ V or 7 V (whichever is less) |
| Digital Outputs to GND | -0.3 V to $DV_{CC} + 0.3$ V or 7 V (whichever is less) |
| REF IN to GND | -0.3 V to +17 V |
| $V_{outA}, V_{outB}, V_{outC}, V_{outD}$ to GND | AV_{SS} to AV_{DD} |
| DAC_GND to GND | -0.3V to +0.3V |
| SIG_GND to GND | -0.3V to +0.3V |
| Operating Temperature Range, T_A | |
| Industrial | -40°C to +85°C |
| Storage Temperature Range | -65°C to +150°C |
| Junction Temperature, T_J max | 105°C |
| 24-Lead TSSOP Package | |
| θ_{JA} Thermal Impedance | 90°C/W |
| Power Dissipation | $(T_J \text{ max} - T_A) / \theta_{JA}$ |
| Lead Temperature | JEDEC Industry Standard |
| Soldering | J-STD-020 |

Stresses above those listed under Absolute Maximum Ratings may cause permanent damage to the device. This is a stress rating only; functional operation of the device at these or any other conditions above those indicated in the operational section of this specification is not implied. Exposure to absolute maximum rating conditions for extended periods may affect device reliability.

ESD CAUTION



ESD (electrostatic discharge) sensitive device. Charged devices and circuit boards can discharge without detection. Although this product features patented or proprietary protection circuitry, damage may occur on devices subjected to high energy ESD. Therefore, proper ESD precautions should be taken to avoid performance degradation or loss of functionality.

PIN CONFIGURATION AND FUNCTION DESCRIPTIONS

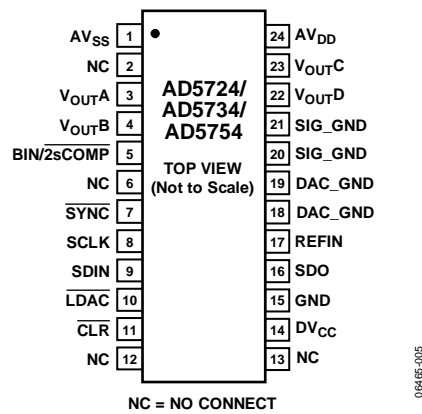

Figure 5. Pin Configuration

Table 7. Pin Function Descriptions

| Pin No. | Mnemonic | Description |
|----------------|-------------------|--|
| 1 | AV _{SS} | Negative Analog Supply Pin. Voltage ranges from -4.5 V to -16.5 V. This pin can be connected to 0 V if output ranges are unipolar. |
| 2, 6, 12, 13 | NC | Do not connect to these pins. |
| 3 | V _{OUTA} | Analog Output Voltage of DAC A. The output amplifier is capable of directly driving a 2 kΩ, 4000 pF load. |
| 4 | V _{OUTB} | Analog Output Voltage of DAC B. The output amplifier is capable of directly driving a 2 kΩ, 4000 pF load. |
| 5 | BIN/2sCOMP | Determines the DAC coding for a bipolar output range. This pin should be hardwired to either DV _{CC} or GND. When hardwired to DV _{CC} , input coding is offset binary. When hardwired to GND, input coding is twos complement. (For unipolar output ranges, coding is always straight binary). |
| 7 | SYNC | Active Low Input. This is the frame synchronization signal for the serial interface. While SYNC is low, data is transferred on the falling edge of SCLK. |
| 8 | SCLK | Serial Clock Input. Data is clocked into the shift register on the falling edge of SCLK. This operates at clock speeds up to 30 MHz. |
| 9 | SDIN | Serial Data Input. Data must be valid on the falling edge of SCLK. |
| 10 | LDAC | Load DAC, Logic Input. This is used to update the DAC registers and consequently, the analog output. When tied permanently low, the addressed DAC register is updated on the rising edge of SYNC. If LDAC is held high during the write cycle, the DAC input register is updated, but the output update is held off until the falling edge of LDAC. In this mode, all analog outputs can be updated simultaneously on the falling edge of LDAC. The LDAC pin should not be left unconnected. |
| 11 | CLR ¹ | Active Low Input. Asserting this pin sets the DAC registers to zero-scale code or mid-scale code (user-selectable). |
| 14 | DV _{CC} | Digital Supply Pin. Voltage ranges from 2.7 V to 5.5 V. |
| 15 | GND | Ground Reference Pin. |
| 16 | SDO | Serial Data Output. Used to clock data from the serial register in daisy-chain or readback mode. Data is clocked out on the rising edge of SCLK and is valid on the falling edge of SCLK. |
| 17 | REFIN | External Reference Voltage Input. Reference input range is 2 V to 3 V. REFIN = 2.5 V for specified performance. |
| 18, 19 | DAC_GND | Ground reference pins for the four digital-to-analog converters. |
| 20, 21 | SIG_GND | Ground reference pins for the four output amplifiers. |
| 22 | V _{OUTD} | Analog Output Voltage of DAC D. The output amplifier is capable of directly driving a 2 kΩ, 4000 pF load. |
| 23 | V _{OUTC} | Analog Output Voltage of DAC C. The output amplifier is capable of directly driving a 2 kΩ, 4000 pF load. |
| 24 | AV _{DD} | Positive Analog Supply Pin. Voltage ranges from 4.5 V to 16.5 V. |
| Exposed Paddle | AV _{SS} | Negative Analog Supply connection. Voltage ranges from -4.5V to -16.5V. This paddle can be connected to 0V if output ranges are unipolar. |

¹ Internal pull-up device on this logic input. Therefore, it can be left floating and defaults to a logic high.

TYPICAL PERFORMANCE CHARACTERISTICS

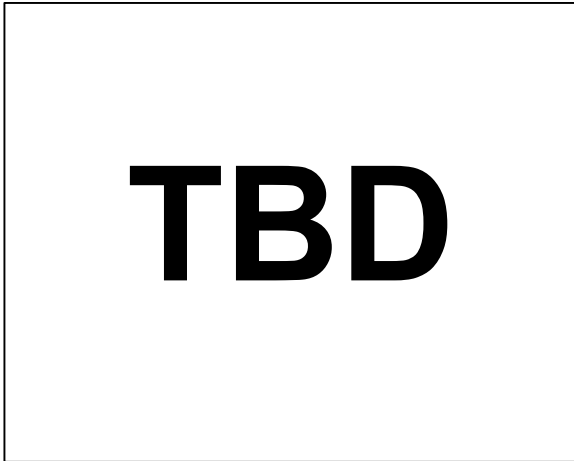

Figure 6. AD5754 Integral Nonlinearity Error vs. Code (Four Traces)

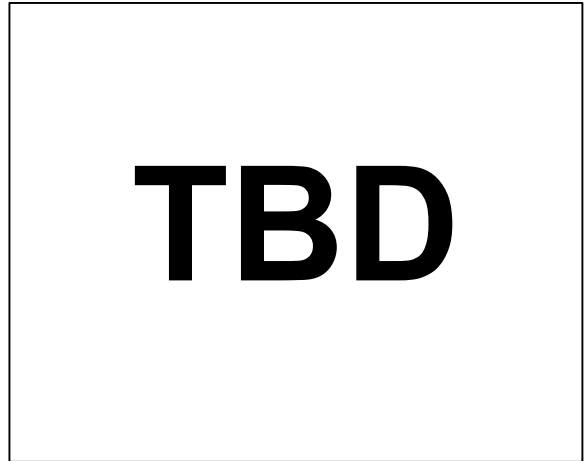

Figure 9. AD5754 Differential Nonlinearity Error vs. Code (Four Traces)

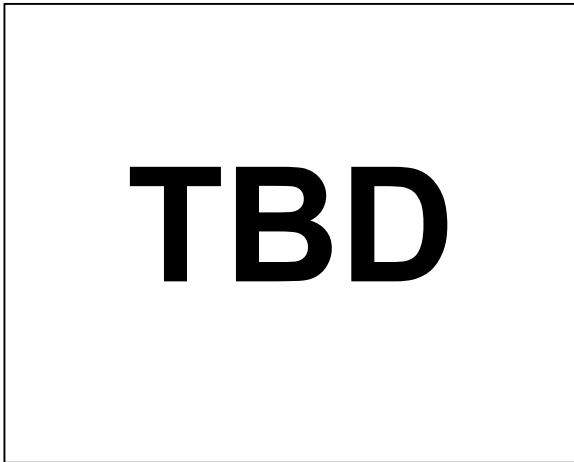

Figure 7. AD5734 Integral Nonlinearity Error vs. Code (Four Traces)

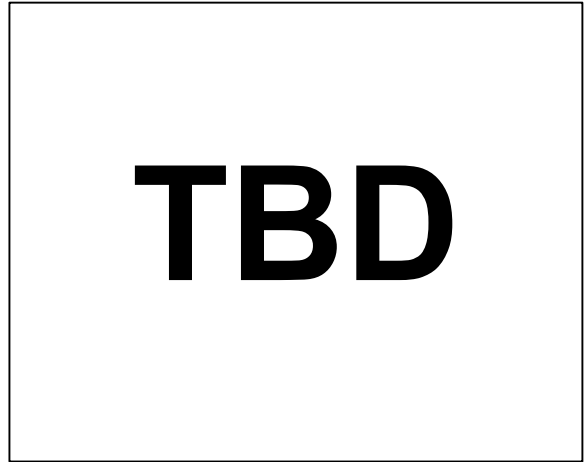

Figure 10. AD5734 Differential Nonlinearity Error vs. Code (Four Traces)

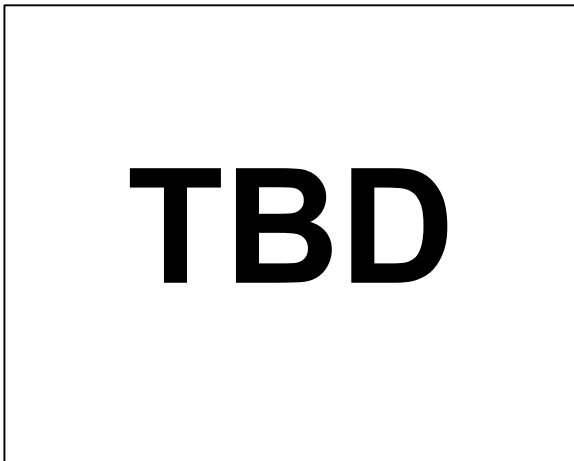

Figure 8. AD5724 Integral Nonlinearity Error vs. Code (Four Traces)

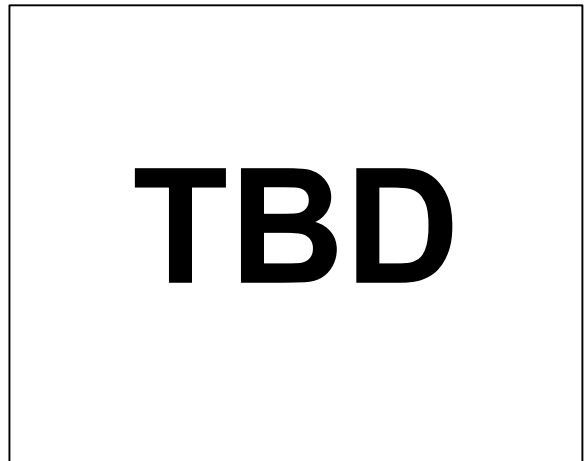

Figure 11. AD5724 Differential Nonlinearity Error vs. Code (Four Traces)

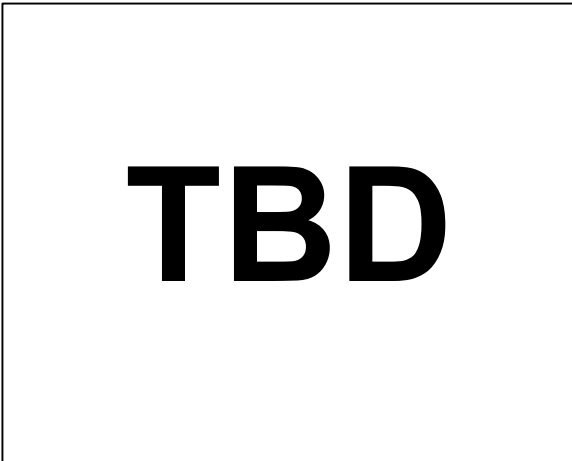

Figure 12. AD5754 Integral Nonlinearity Error vs. Temperature (Four Traces)

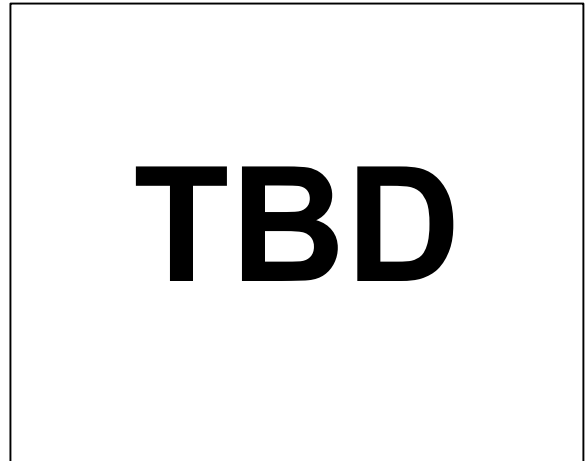

Figure 15. AD5754 Differential Nonlinearity Error vs. Supply Voltage (Four Traces)

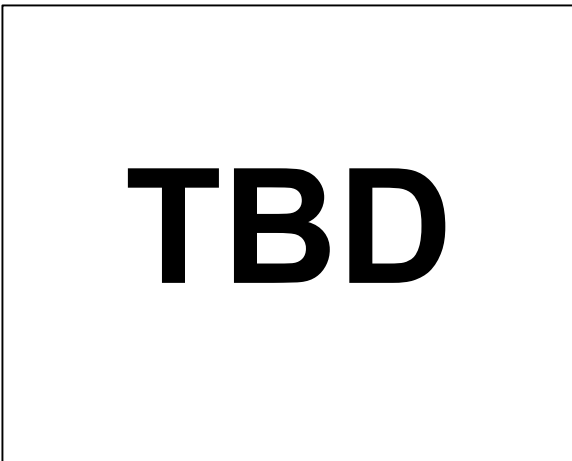

Figure 13. AD5754 Differential Nonlinearity Error vs. Temperature (Four Traces)

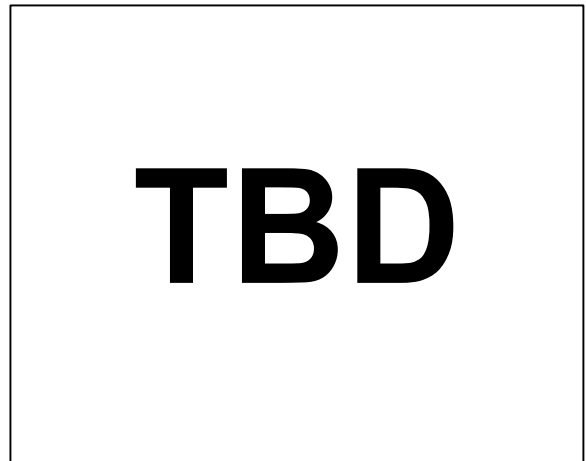

Figure 16. AD5754 Integral Nonlinearity Error vs. Reference Voltage (Four Traces)

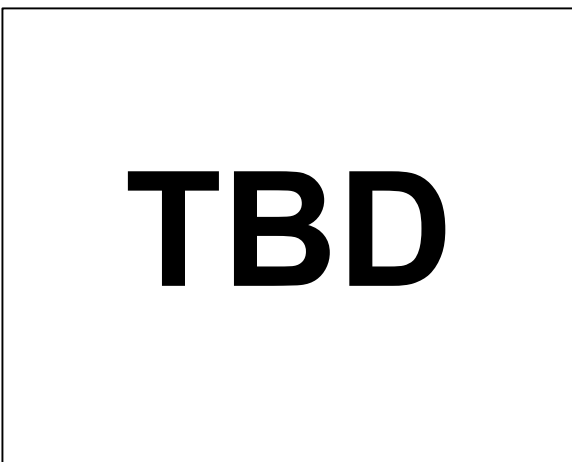

Figure 14. AD5754 Integral Nonlinearity Error vs. Supply Voltage (Four Traces)

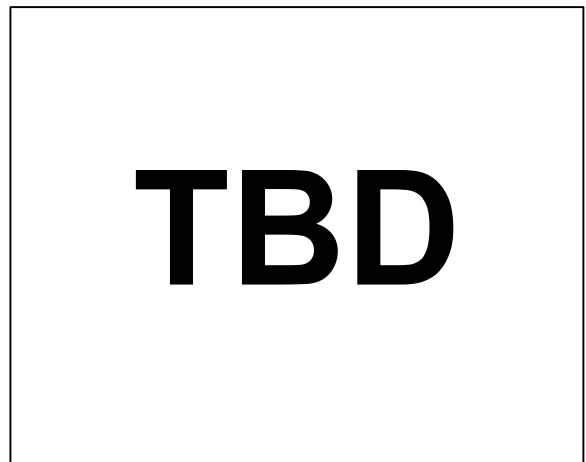

Figure 17. AD5754 Differential Nonlinearity vs. Reference Voltage (Four Traces)

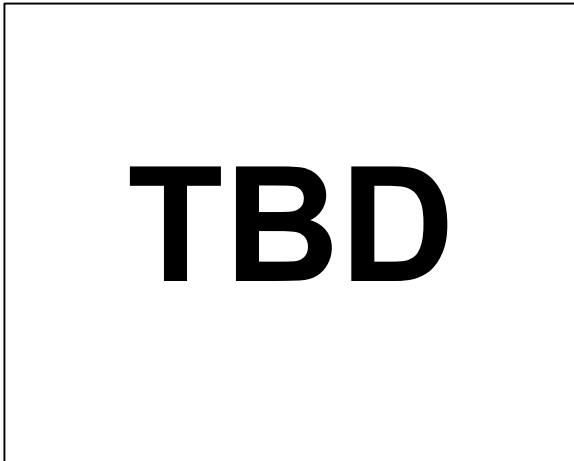

Figure 18. AD5754 Total Unadjusted Error vs. Reference Voltage (Four Traces)

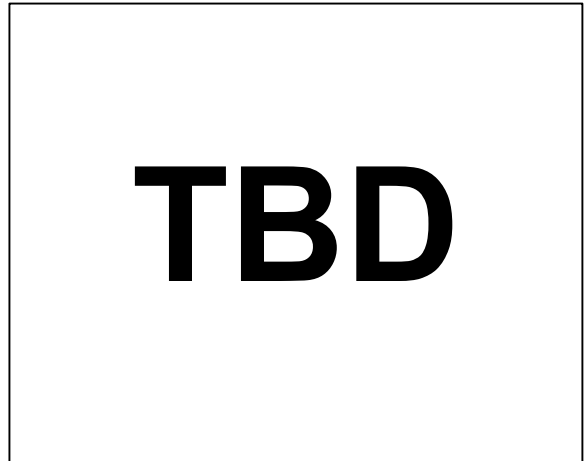

Figure 21. I_{DD} vs. AV_{DD}

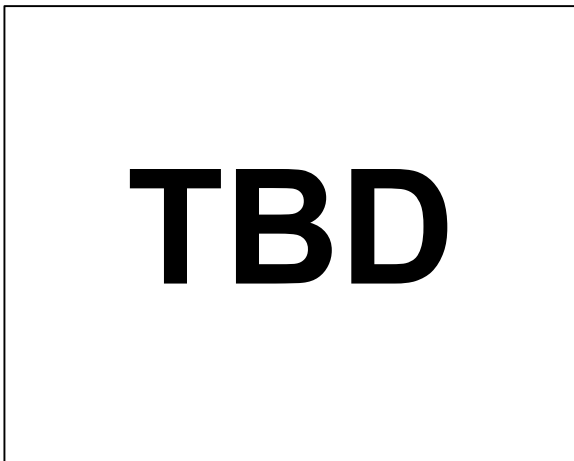

Figure 19. AD5754 Total Unadjusted Error vs. Supply Voltage (Four Traces)

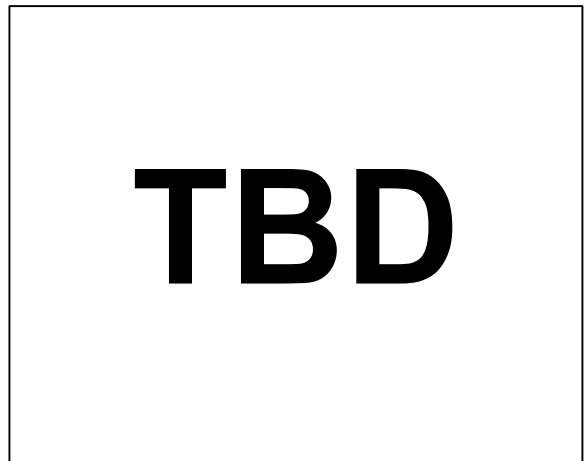

Figure 22. Zero-Scale Error vs. Temperature (Four Traces)

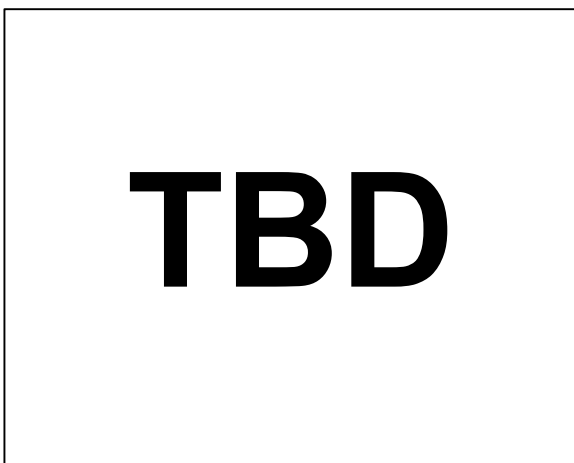

Figure 20. I_{DD}/I_{SS} vs. AV_{DD}/AV_{SS}

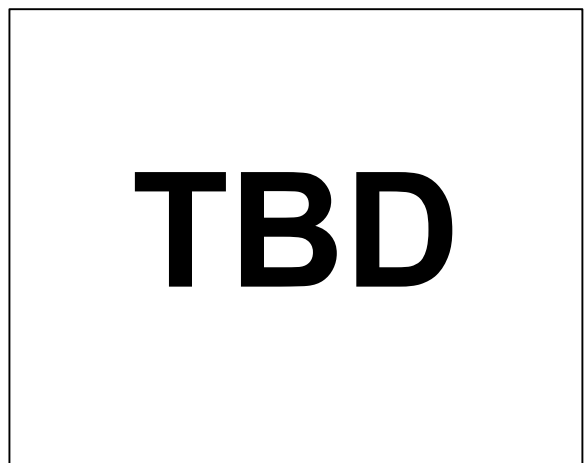

Figure 23. Bipolar Zero Error vs. Temperature (Two Traces)

TBD

Figure 24. Gain Error vs. Temperature (Four Traces)

TBD

Figure 27. Full-Scale Settling Time, ± 10 V Range (Two Traces)

TBD

Figure 25. D_{LCC} vs. Logic Input Voltage Increasing and Decreasing

TBD

Figure 28. Full-Scale Settling Time, ± 5 V Range (Two Traces)

TBD

Figure 26. Output Amplifier Source and Sink Capability (Four Traces)

TBD

Figure 29. Full-Scale Settling Time, $+10$ V Range (Two Traces)

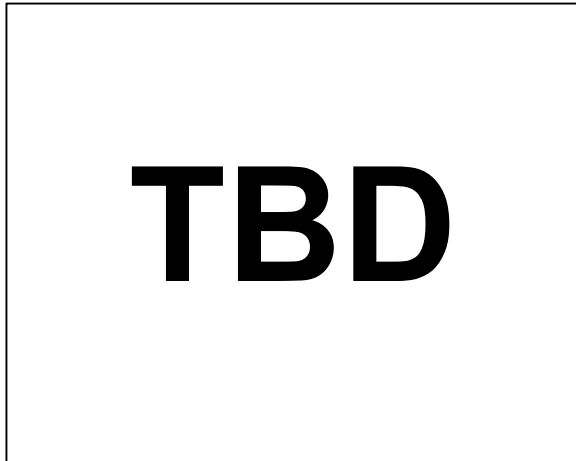

Figure 30. Full-Scale Settling Time, +5 V Range (Two Traces)

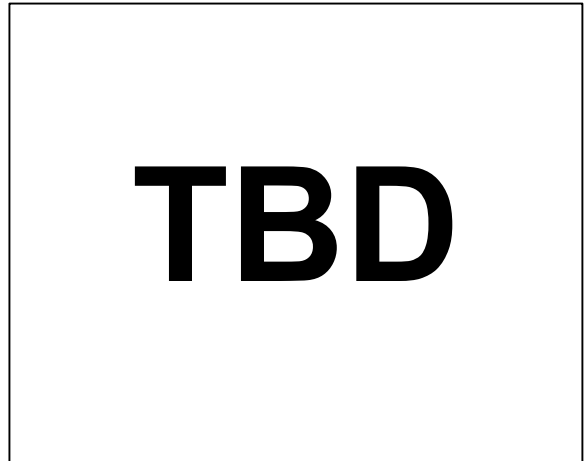

Figure 33. Peak-to-Peak Noise, 100 kHz Bandwidth (Four Traces)

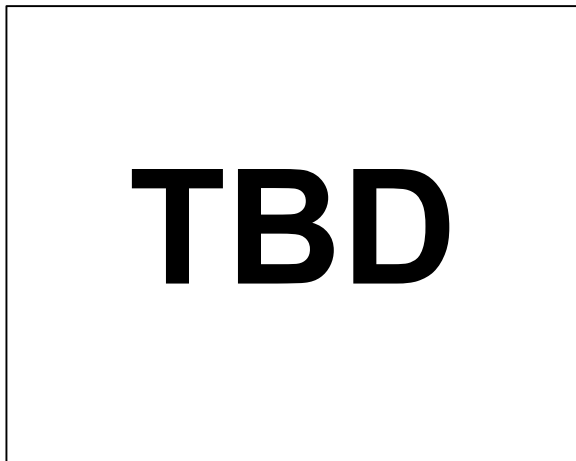

Figure 31. Digital-to-Analog Glitch Energy (Four Traces)

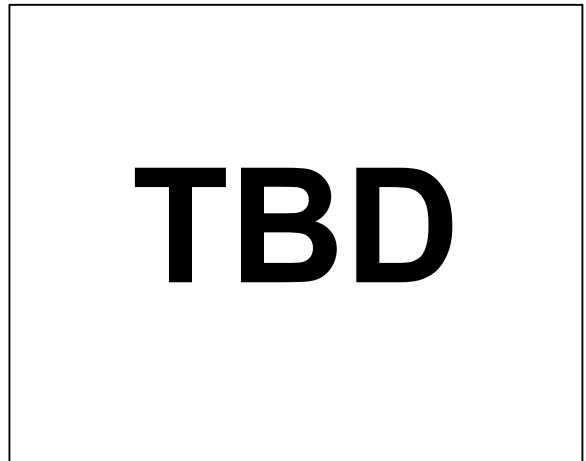

Figure 34. V_{OUT} vs. AV_{DD}/AV_{SS} on Power Up (Two Traces)

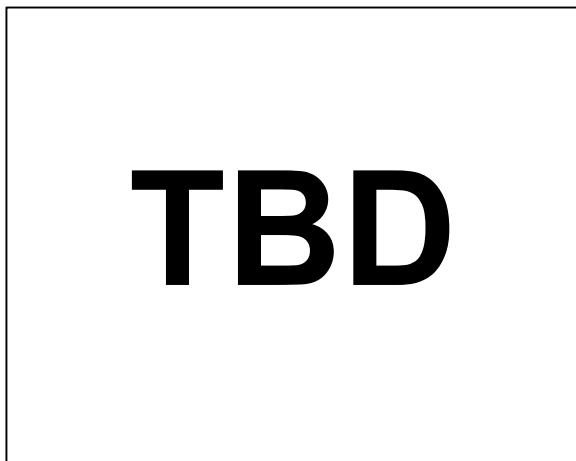

Figure 32. Peak-to-Peak Noise, 0.1 Hz to 10 Hz Bandwidth (Four Traces)

TERMINOLOGY

Relative Accuracy or Integral Nonlinearity (INL)

For the DAC, relative accuracy, or integral nonlinearity, is a measure of the maximum deviation in LSBs from a straight line passing through the endpoints of the DAC transfer function. A typical INL vs. code plot can be seen in Figure 6.

Differential Nonlinearity (DNL)

Differential nonlinearity is the difference between the measured change and the ideal 1 LSB change between any two adjacent codes. A specified differential nonlinearity of ± 1 LSB maximum ensures monotonicity. This DAC is guaranteed monotonic by design. A typical DNL vs. code plot can be seen in Figure 9.

Monotonicity

A DAC is monotonic if the output either increases or remains constant for increasing digital input code. The AD5724/AD5734/AD5754 are monotonic over their full operating temperature range.

Bipolar Zero Error

Bipolar zero error is the deviation of the analog output from the ideal half-scale output of 0 V when the DAC register is loaded with 0x8000 (straight binary coding) or 0x0000 (twos complement coding). A plot of bipolar zero error vs. temperature can be seen in Figure 23.

Bipolar Zero TC

Bipolar Zero TC is a measure of the change in the bipolar zero error with a change in temperature. It is expressed in ppm FSR/ $^{\circ}$ C.

Zero-Scale Error/Negative Full-Scale Error

Zero-scale error is the error in the DAC output voltage when 0x0000 (straight binary coding) or 0x8000 (twos complement coding) is loaded to the DAC register. Ideally, the output voltage should be negative full-scale – 1 LSB. A plot of zero-scale error vs. temperature can be seen in Figure 22.

Zero-Scale TC

This is a measure of the change in zero-scale error with a change in temperature. Zero-Scale TC is expressed in ppm FSR/ $^{\circ}$ C.

Output Voltage Settling Time

Output voltage settling time is the amount of time it takes for the output to settle to a specified level for a full-scale input change. A plot of settling time can be seen in Figure 27.

Slew Rate

The slew rate of a device is a limitation in the rate of change of the output voltage. The output slewing speed of a voltage output D/A converter is usually limited by the slew rate of the amplifier used at its output. Slew rate is measured from 10% to 90% of the output signal and is given in V/ μ s.

Gain Error

This is a measure of the span error of the DAC. It is the deviation in slope of the DAC transfer characteristic from ideal expressed in % FSR. A plot of gain error vs. temperature can be seen in Figure 24.

Gain TC

This is a measure of the change in gain error with changes in temperature. Gain TC is expressed in ppm FSR/ $^{\circ}$ C.

Total Unadjusted Error (TUE)

Total unadjusted error is a measure of the output error taking all the various errors into account, namely INL error, offset error, gain error, and output drift over supplies, temperature, and time. TUE is expressed in % FSR.

Digital-to-Analog Glitch Impulse

Digital-to-analog glitch impulse is the impulse injected into the analog output when the input code in the DAC register changes state, but the output voltage remains constant. It is normally specified as the area of the glitch in nV-sec and is measured when the digital input code is changed by 1 LSB at the major carry transition (0x7FFF to 0x8000). See Figure 31.

Glitch Impulse Peak Amplitude

Glitch impulse peak amplitude is the peak amplitude of the impulse injected into the analog output when the input code in the DAC register changes state. It is specified as the amplitude of the glitch in mV and is measured when the digital input code is changed by 1 LSB at the major carry transition (0x7FFF to 0x8000). See Figure 31.

Digital Feedthrough

Digital feedthrough is a measure of the impulse injected into the analog output of the DAC from the digital inputs of the DAC, but is measured when the DAC output is not updated. It is specified in nV-sec and measured with a full-scale code change on the data bus.

Power Supply Sensitivity

Power supply sensitivity indicates how the output of the DAC is affected by changes in the power supply voltage, it is measured by superimposing a 50/60 Hz, 200mVpk-pk sine wave on the supply voltages and measuring the proportion of the sine wave that transfers to the outputs.

DC Crosstalk

This is the dc change in the output level of one DAC in response to a change in the output of another DAC. It is measured with a full-scale output change on one DAC while monitoring another DAC. It is expressed in LSBs.

Digital Crosstalk

Digital crosstalk is a measure of the impulse injected into the analog output of one DAC from the digital inputs of another DAC, but is measured when the DAC output is not updated. It is specified in nV-sec and measured with a full-scale code change on the data bus.

DAC-to-DAC Crosstalk

DAC-to-DAC crosstalk is the glitch impulse transferred to the output of one DAC due to a digital change and subsequent output change of another DAC. This includes both digital and analog crosstalk. It is measured by loading one of the DACs with a full-scale code change (all 0s to all 1s and vice versa) with $\overline{\text{LDAC}}$ low and monitoring the output of another DAC. The energy of the glitch is expressed in nV-sec.

THEORY OF OPERATION

The AD5724/AD5734/AD5754 are quad, 12-/14-/16-bit, serial input, unipolar/bipolar, voltage output DACs. They operate from unipolar supply voltages of +4.5 V to +16.5 V or bipolar supply voltages of ± 4.5 V to ± 16.5 V. In addition, the parts have software-selectable output ranges of +5 V, +10 V, +10.8 V, ± 5 V, ± 10 V, and ± 10.8 V. Data is written to the AD5724/AD5734/AD5754 in a 24-bit word format via a 3-wire serial interface. The devices also offer an SDO pin to facilitate daisy chaining or readback.

The AD5724/AD5734/AD5754 incorporate a power-on reset circuit to ensure that the DAC registers power up loaded with 0x0000. When powered on, the outputs are clamped to 0 V via a low impedance path.

ARCHITECTURE

The DAC architecture consists of a string DAC followed by an output amplifier. Figure 35 shows a block diagram of the DAC architecture. The reference input is buffered before being applied to the DAC.

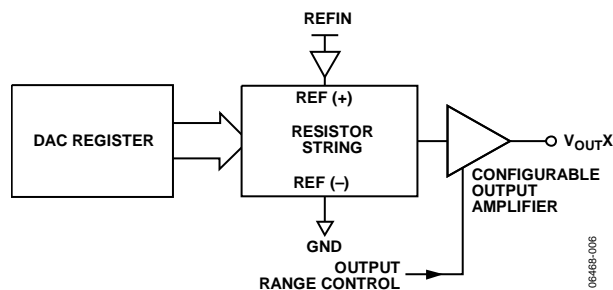

Figure 35. DAC Architecture Block Diagram

The resistor string structure is shown in Figure 36. It is a string of resistors, each of value R . The code loaded to the DAC register determines the node on the string where the voltage is to be tapped off to be fed into the output amplifier. The voltage is tapped off by closing one of the switches connecting the string to the amplifier. Because it is a string of resistors, it is guaranteed monotonic.

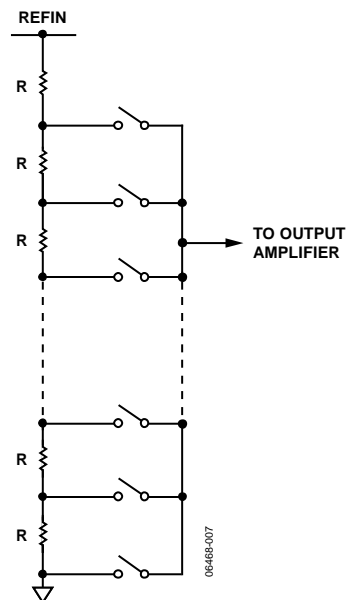

Figure 36. Resistor String Structure

Output Amplifiers

The output amplifiers are capable of generating both unipolar and bipolar output voltages. They are capable of driving a load of 2 k Ω in parallel with 4000 pF to GND. The source and sink capabilities of the output amplifiers can be seen in Figure 26. The slew rate is 4.5 V/ μ s with a full-scale settling time of 10 μ s.

Reference Buffers

The AD5724/AD5734/AD5754 require an external reference source. The reference input has an input range of 2 V to 3 V with 2.5 V for specified performance. This input voltage is then buffered before it is applied to the DAC cores.

SERIAL INTERFACE

The AD5724/AD5734/AD5754 are controlled over a versatile 3-wire serial interface that operates at clock rates up to 30 MHz. It is compatible with SPI[®], QSPI[™], MICROWIRE[™], and DSP standards.

Input Shift Register

The input shift register is 24 bits wide. Data is loaded into the device MSB first as a 24-bit word under the control of a serial clock input, SCLK. The input register consists of a read/write bit, three register select bits, three DAC address bits, and 16 data bits. The timing diagram for this operation is shown in Figure 2.

Standalone Operation

The serial interface works with both a continuous and noncontinuous serial clock. A continuous SCLK source can only be used if SYNC is held low for the correct number of clock cycles. In gated clock mode, a burst clock containing the exact number of clock cycles must be used, and SYNC must be taken high after the final clock to latch the data. The first falling edge of SYNC starts the write cycle. Exactly 24 falling clock edges must be applied to SCLK before SYNC is brought high again. If SYNC is brought high before the 24th falling SCLK edge, the data written is invalid. If more than 24 falling SCLK edges are applied before SYNC is brought high, the input data is also invalid. The input register addressed is updated on the rising edge of SYNC. For another serial transfer to take place, SYNC must be brought low again. After the end of the serial data transfer, data is automatically transferred from the input shift register to the addressed register.

When the data has been transferred into the chosen register of the addressed DAC, all DAC registers and outputs can be updated by taking LDAC low while SYNC is high.

Daisy-Chain Operation

For systems that contain several devices, the SDO pin can be used to daisy chain several devices together. Daisy-chain mode can be useful in system diagnostics and in reducing the number of serial interface lines. The first falling edge of SYNC starts the write cycle. SCLK is continuously applied to the input shift register when SYNC is low. If more than 24 clock pulses are applied, the data ripples out of the shift register and appears on the SDO line. This data is clocked out on the rising edge of SCLK and is valid on the falling edge. By connecting the SDO of the first device to the SDIN input of the next device in the chain, a multidevice interface is constructed. Each device in the system requires 24 clock pulses. Therefore, the total number of clock cycles must equal $24 \times N$, where N is the total number of AD5724/AD5734/AD5754 devices in the chain. When the serial transfer to all devices is complete, SYNC is taken high. This latches the input data in each device in the daisy chain and prevents any further data from being clocked into the input shift register. The serial clock can be a continuous or a gated clock.

A continuous SCLK source can only be used if SYNC is held low for the correct number of clock cycles. In gated clock mode, a burst clock containing the exact number of clock cycles must be used, and SYNC must be taken high after the final clock to latch the data.

Readback Operation

Readback mode is invoked by setting the R/W bit = 1 in the serial input register write. (If the SDO output is disabled via the SDO DISABLE bit in the control register, it is automatically enabled for the duration of the read operation after which it is disabled again). With $R/\overline{W} = 1$, Bit A2 to Bit A0 in association with Bit REG2 to Bit REG0 select the register to be read. The remaining data bits in the write sequence are don't care bits. During the next SPI write, the data appearing on the SDO output contains the data from the previously addressed register. For a read of a single register, the NOP command can be used in clocking out the data from the selected register on SDO. The readback diagram in Figure 4 shows the readback sequence. For example, to read back the data register of Channel A, the following sequence should be implemented:

1. Write 0x800000 to the AD5724/AD5734/AD5754 input register. This configures the part for read mode with the data register of Channel A selected. Note that all the data bits, DB15 to DB0, are don't care bits.
2. Follow this with a second write, a NOP condition, 0x180000. During this write, the data from the register is clocked out on the SDO line.

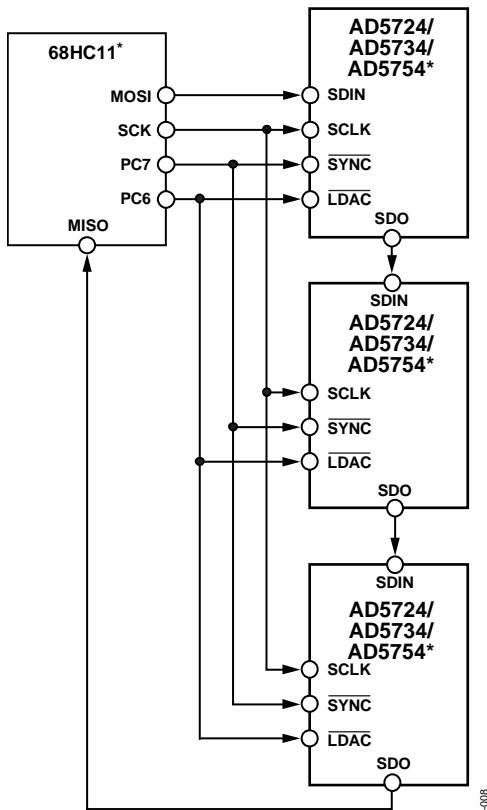

*ADDITIONAL PINS OMITTED FOR CLARITY. Figure 37. Daisy Chaining the AD5724/AD5734/AD5754

LOAD DAC ($\overline{\text{LDAC}}$)

After data has been transferred into the input register of the DACs, there are two ways to update the DAC registers and DAC outputs. Depending on the status of both $\overline{\text{SYNC}}$ and $\overline{\text{LDAC}}$, one of two update modes is selected: individual DAC updating or simultaneous updating of all DACs.

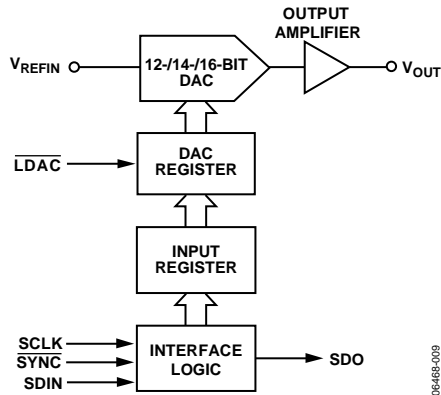

Figure 38. Simplified Diagram of Input Loading Circuitry for One DAC

Individual DAC Updating

In this mode, $\overline{\text{LDAC}}$ is held low while data is being clocked into the input shift register. The addressed DAC output is updated on the rising edge of $\overline{\text{SYNC}}$.

Simultaneous Updating of All DACs

In this mode, $\overline{\text{LDAC}}$ is held high while data is being clocked into the input shift register. All DAC outputs are asynchronously updated by taking $\overline{\text{LDAC}}$ low after $\overline{\text{SYNC}}$ has been taken high. The update now occurs on the falling edge of $\overline{\text{LDAC}}$.

ASYNCHRONOUS CLEAR ($\overline{\text{CLR}}$)

$\overline{\text{CLR}}$ is an active low clear that allows the outputs to be cleared to either zero-scale code or mid-scale code. The clear code value is user-selectable via the CLR SELECT bit of the control register (see the Control Register section). It is necessary to maintain $\overline{\text{CLR}}$ low for a minimum amount of time (see Figure 2) to complete the operation. When the $\overline{\text{CLR}}$ signal is returned high, the output remains at the cleared value until a new value is programmed. The outputs cannot be updated with a new value while the $\overline{\text{CLR}}$ pin is low. A clear operation can also be performed via the clear command in the control register.

CONFIGURING THE AD5724/AD5734/AD5754

When the power supplies are applied to the AD5724/AD5734/AD5754, the power-on reset circuit ensures that all registers default to 0. This places all channels in power-down mode. The first communication to the AD5724/AD5734/AD5754 should be to set the required output range on all channels (default range is the 5 V unipolar range) by writing to the range select register. The user should then write to the power-control register to power-on the required channels. To program an output value on a channel, that channel must first be powered up; any writes to a channel while it is in power-down mode are ignored. The AD5724/AD5734/AD5754 operate with a wide power supply range. It is important that the power supply applied to the parts provides adequate headroom to support the chosen output ranges.

TRANSFER FUNCTION

Table 9 to Table 17 show the relationships of the ideal input code to output voltage for the AD5754, AD5734, and AD5724, respectively, for all output voltage ranges. For unipolar output ranges, the data coding is straight binary. For bipolar output ranges, the data coding is user-selectable via the BIN/2sCOMP pin and can be either offset binary or twos complement.

For a unipolar output range, the output voltage expression is given by

$$V_{OUT} = V_{REFIN} \times Gain \left[\frac{D}{2^N} \right]$$

For a bipolar output range, the output voltage expression is given by

$$V_{OUT} = V_{REFIN} \times Gain \left[\frac{D}{2^N} \right] - \frac{Gain \times V_{REFIN}}{2}$$

where:

D is the decimal equivalent of the code loaded to the DAC.

N is the bit resolution of the DAC.

V_{REFIN} is the reference voltage applied at the REFIN pin.

$Gain$ is an internal gain whose value depends on the output range selected by the user as shown in Table 8.

Table 8.

| Output Range | Gain Value |
|--------------|------------|
| +5 V | 2 |
| +10 V | 4 |
| +10.8 V | 4.32 |
| ±5 V | 4 |
| ±10 V | 8 |
| ±10.8 V | 8.64 |

Ideal Output Voltage to Input Code Relationship—AD5754

Table 9. Bipolar Output, Offset Binary Coding

| Digital Input | | | | Analog Output | | |
|---------------|------|------|------|-----------------------|-----------------------|--------------------------|
| MSB | | | LSB | ±5 V Output Range | ±10 V Output Range | ±10.8 V Output Range |
| 1111 | 1111 | 1111 | 1111 | +2 REFIN(32767/32768) | +4 REFIN(32767/32768) | +4.32 REFIN(32767/32768) |
| 1111 | 1111 | 1111 | 1110 | +2 REFIN(32766/32768) | +4 REFIN(32766/32768) | +4.32 REFIN(32766/32768) |
| – | – | – | – | – | – | – |
| 1000 | 0000 | 0000 | 0001 | +2 REFIN(1/32768) | +4 REFIN(1/32768) | +4.32 REFIN(1/32768) |
| 1000 | 0000 | 0000 | 0000 | 0 V | 0 V | 0 V |
| 0111 | 1111 | 1111 | 1111 | –2 REFIN(1/32768) | –4 REFIN(1/32768) | –4.32 REFIN(32766/32768) |
| – | – | – | – | – | – | – |
| 0000 | 0000 | 0000 | 0001 | –2 REFIN(32766/32768) | –4 REFIN(32766/32768) | –4.32 REFIN(32766/32768) |
| 0000 | 0000 | 0000 | 0000 | –2 REFIN(32767/32768) | –4 REFIN(32767/32768) | –4.32 REFIN(32767/32768) |

Table 10. Bipolar Output, Twos Complement Coding

| Digital Input | | | | Analog Output | | |
|---------------|------|------|------|-----------------------|-----------------------|--------------------------|
| MSB | | | LSB | ±5 V Output Range | ±10 V Output Range | ±10.8 V Output Range |
| 0111 | 1111 | 1111 | 1111 | +2 REFIN(32767/32768) | +4 REFIN(32767/32768) | +4.32 REFIN(32767/32768) |
| 0111 | 1111 | 1111 | 1110 | +2 REFIN(32766/32768) | +4 REFIN(32766/32768) | +4.32 REFIN(32766/32768) |
| – | – | – | – | – | – | – |
| 0000 | 0000 | 0000 | 0001 | +2 REFIN(1/32768) | +4 REFIN(1/32768) | +4.32 REFIN(1/32768) |
| 0000 | 0000 | 0000 | 0000 | 0 V | 0 V | 0 V |
| 1111 | 1111 | 1111 | 1111 | –2 REFIN(1/32768) | –4 REFIN(1/32768) | –4.32 REFIN(1/32768) |
| – | – | – | – | – | – | – |
| 1000 | 0000 | 0000 | 0001 | –2 REFIN(32766/32768) | –4 REFIN(32766/32768) | –4.32 REFIN(32766/32768) |
| 1000 | 0000 | 0000 | 0000 | –2 REFIN(32767/32768) | –4 REFIN(32767/32768) | –4.32 REFIN(32767/32768) |

Table 11. Unipolar Output, Straight Binary Coding

| Digital Input | | | | Analog Input | | |
|---------------|------|------|------|-----------------------|-----------------------|--------------------------|
| MSB | | | LSB | +5 V Output Range | +10 V Output Range | +10.8 V Output Range |
| 1111 | 1111 | 1111 | 1111 | +2 REFIN(65535/65536) | +4 REFIN(65535/65536) | +4.32 REFIN(65535/65536) |
| 1111 | 1111 | 1111 | 1110 | +2 REFIN(65534/65536) | +4 REFIN(65534/65536) | +4.32 REFIN(65534/65536) |
| – | – | – | – | – | – | – |
| 1000 | 0000 | 0000 | 0001 | +2 REFIN(32769/65536) | +4 REFIN(32769/65536) | +4.32 REFIN(32769/65536) |
| 1000 | 0000 | 0000 | 0000 | +2 REFIN(32768/65536) | +4 REFIN(32768/65536) | +4.32 REFIN(32768/65536) |
| 0111 | 1111 | 1111 | 1111 | +2 REFIN(32767/65536) | +4 REFIN(32767/65536) | +4.32 REFIN(32767/65536) |
| – | – | – | – | – | – | – |
| 0000 | 0000 | 0000 | 0001 | +2 REFIN(1/65536) | +4 REFIN(1/65536) | +4.32 REFIN(1/65536) |
| 0000 | 0000 | 0000 | 0000 | 0 V | 0 V | 0 V |

Ideal Output Voltage to Input Code Relationship—AD5734

Table 12. Bipolar Output, Offset Binary Coding

| Digital Input | | | | Analog Output | | |
|---------------|------|------|------|---------------------|---------------------|------------------------|
| MSB | | | LSB | ±5 V Output Range | ±10 V Output Range | ±10.8 V Output Range |
| 11 | 1111 | 1111 | 1111 | +2 REFIN(8191/8192) | +4 REFIN(8191/8192) | +4.32 REFIN(8191/8192) |
| 11 | 1111 | 1111 | 1110 | +2 REFIN(8190/8192) | +4 REFIN(8190/8192) | +4.32 REFIN(8190/8192) |
| – | – | – | – | – | – | – |
| 10 | 0000 | 0000 | 0001 | +2 REFIN(1/8192) | +4 REFIN(1/8192) | +4 REFIN(1/8192) |
| 10 | 0000 | 0000 | 0000 | 0 V | 0 V | 0 V |
| 01 | 1111 | 1111 | 1111 | –2 REFIN(1/8192) | –4 REFIN(1/8192) | –4.32 REFIN(1/8192) |
| – | – | – | – | – | – | – |
| 00 | 0000 | 0000 | 0001 | –2 REFIN(8190/8192) | –4 REFIN(8190/8192) | –4.32 REFIN(8190/8192) |
| 00 | 0000 | 0000 | 0000 | –2 REFIN(8191/8191) | –4 REFIN(8191/8192) | –4.32 REFIN(8191/8192) |

Table 13. Bipolar Output, Twos Complement Coding

| Digital Input | | | | Analog Output | | |
|---------------|------|------|------|---------------------|---------------------|------------------------|
| MSB | | | LSB | ±5 V Output Range | ±10 V Output Range | ±10.8 V Output Range |
| 01 | 1111 | 1111 | 1111 | +2 REFIN(8191/8192) | +4 REFIN(8191/8192) | +4.32 REFIN(8191/8192) |
| 01 | 1111 | 1111 | 1110 | +2 REFIN(8190/8192) | +4 REFIN(8190/8192) | +4.32 REFIN(8190/8192) |
| – | – | – | – | – | – | – |
| 00 | 0000 | 0000 | 0001 | +2 REFIN(1/8192) | +4 REFIN(1/8192) | +4 REFIN(1/8192) |
| 00 | 0000 | 0000 | 0000 | 0 V | 0 V | 0 V |
| 11 | 1111 | 1111 | 1111 | –2 REFIN(1/8192) | –4 REFIN(1/8192) | –4.32 REFIN(1/8192) |
| – | – | – | – | – | – | – |
| 10 | 0000 | 0000 | 0001 | –2 REFIN(8190/8192) | –4 REFIN(8190/8192) | –4.32 REFIN(8190/8192) |
| 10 | 0000 | 0000 | 0000 | –2 REFIN(8191/8192) | –4 REFIN(8191/8192) | –4.32 REFIN(8191/8192) |

Table 14. Unipolar Output, Straight Binary Coding

| Digital Input | | | | Analog Output | | |
|---------------|------|------|------|-----------------------|-----------------------|--------------------------|
| MSB | | | LSB | ±5 V Output Range | ±10 V Output Range | ±10.8 V Output Range |
| 11 | 1111 | 1111 | 1111 | +2 REFIN(16383/16384) | +4 REFIN(16383/16384) | +4.32 REFIN(16383/16384) |
| 11 | 1111 | 1111 | 1110 | +2 REFIN(16382/16384) | +4 REFIN(16382/16384) | +4.32 REFIN(16382/16384) |
| – | – | – | – | – | – | – |
| 10 | 0000 | 0000 | 0001 | +2 REFIN(8193/16384) | +4 REFIN(8193/16384) | +4.32 REFIN(8193/16384) |
| 10 | 0000 | 0000 | 0000 | +2 REFIN(8192/16384) | +4 REFIN(8192/16384) | +4.32 REFIN(8192/16384) |
| 01 | 1111 | 1111 | 1111 | +2 REFIN(8191/16384) | +4 REFIN(8191/16384) | +4.32 REFIN(8191/16384) |
| – | – | – | – | – | – | – |
| 00 | 0000 | 0000 | 0001 | +2 REFIN(1/16384) | +4 REFIN(1/16384) | +4.32 REFIN(1/16384) |
| 00 | 0000 | 0000 | 0000 | 0 V | 0 V | 0 V |

Ideal Output Voltage to Input Code Relationship—AD5724

Table 15. Bipolar Output, Offset Binary Coding

| Digital Input | | | Analog Output | | |
|---------------|------|------|---------------------|---------------------|------------------------|
| MSB | LSB | | ±5 V Output Range | ±10 V Output Range | ±10.8 V Output Range |
| 1111 | 1111 | 1111 | +2 REFIN(2047/2048) | +4 REFIN(2047/2048) | +4.32 REFIN(2047/2048) |
| 1111 | 1111 | 1110 | +2 REFIN(2046/2048) | +4 REFIN(2046/2048) | +4.32 REFIN(2046/2048) |
| – | – | – | – | – | – |
| 1000 | 0000 | 0001 | +2 REFIN(1/2048) | +4 REFIN(1/2048) | +4 REFIN(1/2048) |
| 1000 | 0000 | 0000 | 0 V | 0 V | 0 V |
| 0111 | 1111 | 1111 | –2 REFIN(1/2048) | –4 REFIN(1/2048) | –4.32 REFIN(1/2048) |
| – | – | – | – | – | – |
| 0000 | 0000 | 0001 | –2 REFIN(2046/2048) | –4 REFIN(2046/2048) | –4.32 REFIN(2046/2048) |
| 0000 | 0000 | 0000 | –2 REFIN(2047/2047) | –4 REFIN(2047/2048) | –4.32 REFIN(2047/2048) |

Table 16. Bipolar Output, Twos Complement Coding

| Bipolar Output | | | Analog Output | | |
|----------------|------|------|---------------------|---------------------|------------------------|
| MSB | LSB | | ±5 V Output Range | ±10 V Output Range | ±10.8 V Output Range |
| 0111 | 1111 | 1111 | +2 REFIN(2047/2048) | +4 REFIN(2047/2048) | +4.32 REFIN(2047/2048) |
| 0111 | 1111 | 1110 | +2 REFIN(2046/2048) | +4 REFIN(2046/2048) | +4.32 REFIN(2046/2048) |
| – | – | – | – | – | – |
| 0000 | 0000 | 0001 | +2 REFIN(1/2048) | +4 REFIN(1/2048) | +4 REFIN(1/2048) |
| 0000 | 0000 | 0000 | 0 V | 0 V | 0 V |
| 1111 | 1111 | 1111 | –2 REFIN(1/2048) | –4 REFIN(1/2048) | –4.32 REFIN(1/2048) |
| – | – | – | – | – | – |
| 1000 | 0000 | 0001 | –2 REFIN(2046/2048) | –4 REFIN(2046/2048) | –4.32 REFIN(2046/2048) |
| 1000 | 0000 | 0000 | –2 REFIN(2047/2048) | –4 REFIN(2047/2048) | –4.32 REFIN(2047/2048) |

Table 17. Unipolar Output, Straight Binary Coding

| Digital Input | | | Analog Output | | |
|---------------|------|------|---------------------|---------------------|------------------------|
| MSB | LSB | | +5 V Output Range | +10 V Output Range | +10.8 V Output Range |
| 1111 | 1111 | 1111 | +2 REFIN(4095/4096) | +4 REFIN(4095/4096) | +4.32 REFIN(4095/4096) |
| 1111 | 1111 | 1110 | +2 REFIN(4094/4096) | +4 REFIN(4094/4096) | +4.32 REFIN(4094/4096) |
| – | – | – | – | – | – |
| 1000 | 0000 | 0001 | +2 REFIN(2049/4096) | +4 REFIN(2049/4096) | +4.32 REFIN(2049/4096) |
| 1000 | 0000 | 0000 | +2 REFIN(2048/4096) | +4 REFIN(2048/4096) | +4.32 REFIN(2048/4096) |
| 0111 | 1111 | 1111 | +2 REFIN(2047/4096) | +4 REFIN(2047/4096) | +4.32 REFIN(2047/4096) |
| – | – | – | – | – | – |
| 0000 | 0000 | 0001 | +2 REFIN(1/4096) | +4 REFIN(1/4096) | 4.32 REFIN(1/4096) |
| 0000 | 0000 | 0000 | 0 V | 0 V | 0 V |

INPUT REGISTER

The input register is 24 bits wide and consists of a read/write bit, a reserved bit, three register select bits, three DAC address bits, and up to 12-/14-/16 data bits. The register data is clocked in MSB first on the SDIN pin. Table 18 shows the register format while Table 19 describes the function of each bit in the register. All registers are read/write registers.

Table 18. Input Register Format

| MSB | | | | | | | LSB | |
|------|------|------|------|------|------|------|------|-------------|
| DB23 | DB22 | DB21 | DB20 | DB19 | DB18 | DB17 | DB16 | DB15 to DB0 |
| R/W | 0 | REG2 | REG1 | REG0 | A2 | A1 | A0 | DATA |

Table 19. Input Register Bit Functions

| Bit Mnemonic | Description | | | |
|------------------|--|------|------|------------------------------|
| R/W | Indicates a read from or a write to the addressed register. | | | |
| REG2, REG1, REG0 | Used in association with the address bits to determine if a write operation is to the data register, output range select register, power control register or control register. | | | |
| | REG2 | REG1 | REG0 | Function |
| | 0 | 0 | 0 | Data Register |
| | 0 | 0 | 1 | Output Range Select Register |
| | 0 | 1 | 0 | Power Control Register |
| | 0 | 1 | 1 | Control Register |
| A2, A1, A0 | These bits are used to decode the DAC channels. | | | |
| | A2 | A1 | A0 | Channel Address |
| | 0 | 0 | 0 | DAC A |
| | 0 | 0 | 1 | DAC B |
| | 0 | 1 | 0 | DAC C |
| | 0 | 1 | 1 | DAC D |
| | 1 | 0 | 0 | All Four DACs |
| DB15 to DB0 | Data bits. | | | |

DATA REGISTER

The data register is addressed by setting the three REG bits to 000. The DAC address bits select the DAC channel where the data transfer is to take place (see Table 19). The data bits are in positions DB15 to DB0 for the AD5754 (See Table 20), DB15 to DB2 for the AD5734 (See Table 21), and DB15 to DB4 for the AD5724 (See Table 22).

Table 20. Programming the AD5754 Data Register

| MSB | | | | | | LSB | |
|------|------|------|-------------|----|----|-----------------|--|
| REG2 | REG1 | REG0 | A2 | A1 | A0 | DB15 to DB0 | |
| 0 | 0 | 0 | DAC Address | | | 16-Bit DAC Data | |

Table 21. Programming the AD5734 Data Register

| MSB | | | | | | LSB | | |
|------|------|------|-------------|----|----|-----------------|-----|-----|
| REG2 | REG1 | REG0 | A2 | A1 | A0 | DB15 to DB2 | DB1 | DB0 |
| 0 | 0 | 0 | DAC Address | | | 14-Bit DAC Data | X | X |

Table 22. Programming the AD5724 Data Register

| MSB | | | | | | LSB | | | | |
|------|------|------|-------------|----|----|-----------------|-----|-----|-----|-----|
| REG2 | REG1 | REG0 | A2 | A1 | A0 | DB15 to DB4 | DB3 | DB2 | DB1 | DB0 |
| 0 | 0 | 0 | DAC Address | | | 12-Bit DAC Data | X | X | X | X |

OUTPUT RANGE SELECT REGISTER

The output range select register is addressed by setting the three REG bits to 001. The DAC address bits select the DAC channel, while, the range bits (R2, R1, R0) select the required output range (See Table 23 and Table 24).

Table 23. Programming the Required Output Range

| MSB | | | | | | LSB | | | |
|------|------|------|-------------|----|----|-------------|-----|-----|-----|
| REG2 | REG1 | REG0 | A2 | A1 | A0 | DB15 to DB3 | DB2 | DB1 | DB0 |
| 0 | 0 | 0 | DAC Address | | | Don't Care | R2 | R1 | R0 |

Table 24. Output Range Options

| R2 | R1 | R0 | Output Range |
|----|----|----|--------------|
| 0 | 0 | 0 | +5 V |
| 0 | 0 | 1 | +10 V |
| 0 | 1 | 0 | +10.8 V |
| 0 | 1 | 1 | ±5 V |
| 1 | 0 | 0 | ±10 V |
| 1 | 0 | 1 | ±10.8 V |

CONTROL REGISTER

The control register is addressed by setting the three REG bits to 011. The value written to the address and data bits determines the control function selected. The control register options are shown in Table 25 and Table 26.

Table 25. Control Register Format

| MSB | | | | | | LSB | | | | |
|------|------|------|----|----|----|--------------------------|------------|--------------|------------|-------------|
| REG2 | REG1 | REG0 | A2 | A1 | A0 | DB15 to DB4 | DB3 | DB2 | DB1 | DB0 |
| 0 | 1 | 1 | 0 | 0 | 0 | NOP, Data = Don't Care | | | | |
| 0 | 1 | 1 | 0 | 0 | 1 | Don't Care | TSD ENABLE | CLAMP ENABLE | CLR SELECT | SDO DISABLE |
| 0 | 1 | 1 | 1 | 0 | 0 | CLEAR, Data = Don't Care | | | | |
| 0 | 1 | 1 | 1 | 0 | 1 | LOAD, Data = Don't Care | | | | |

Table 26. Explanation of Control Register Options

| Option | Description |
|--------------|--|
| NOP | No operation instruction used in readback operations. |
| CLEAR | Addressing this function sets the DAC registers to the clear code and updates the outputs. |
| LOAD | Addressing this function updates the DAC registers and consequently, the DAC outputs. |
| SDO DISABLE | Set by the user to disable the SDO output. Cleared by the user to enable the SDO output (default). |
| CLR SELECT | See Table 27 for a description of the CLR SELECT operation. |
| CLAMP ENABLE | Set by the user to enable the current limit clamp (default). The channel does not power down on detection of overcurrent; the current is clamped at 20 mA. Cleared by the user to disable the current-limit clamp. The channel powers down on detection of overcurrent. |
| TSD ENABLE | Set by the user to enable the thermal shutdown feature. Cleared by the user to disable the thermal shutdown feature (default). |

Table 27. CLR Select Options

| CLR SELECT | Output CLR Value | |
|------------|-----------------------|----------------------|
| | Unipolar Output Range | Bipolar Output Range |
| 0 | 0 V | 0 V |
| 1 | Mid-Scale | Negative Full-Scale |

POWER CONTROL REGISTER

The power control register is addressed by setting the three REG bits to 010. This register allows the user to control and determine the power and thermal status of the AD5724/AD5734/AD5754. The power control register options are shown in Table 28 and Table 29.

Table 28. Power Control Register Format

| MSB | | | | | | | | | | | | | | | | LSB | |
|------|------|------|----|----|----|--------------|-----------------|-----------------|-----------------|-----------------|-----|-----|-----|-----------------|-----------------|-----------------|-----------------|
| REG2 | REG1 | REG0 | A2 | A1 | A0 | DB15 to DB11 | DB10 | DB9 | DB8 | DB7 | DB6 | DB5 | DB4 | DB3 | DB2 | DB1 | DB0 |
| 0 | 1 | 0 | 0 | 0 | 0 | Don't Care | OC _D | OC _C | OC _B | OC _A | 0 | TSD | 0 | PU _D | PU _C | PU _B | PU _A |

Table 29. Power Control Register Functions

| Option | Description |
|-----------------|---|
| PU _A | DAC A Power-Up. When set, this bit places DAC A in normal operating mode. When cleared, this bit places DAC A in power-down mode (default). If the CLAMP ENABLE bit of the control register is cleared, DAC A will power down automatically on detection of an over-current, PU _A will be cleared to reflect this. |
| PU _B | DAC B Power-Up. When set, this bit places DAC B in normal operating mode. When cleared, this bit places DAC B in power-down mode (default). If the CLAMP ENABLE bit of the control register is cleared, DAC B will power down automatically on detection of an over-current, PU _B will be cleared to reflect this. |
| PU _C | DAC C Power-Up. When set, this bit places DAC C in normal operating mode. When cleared, this bit places DAC C in power-down mode (default). If the CLAMP ENABLE bit of the control register is cleared, DAC C will power down automatically on detection of an over-current, PU _C will be cleared to reflect this. |
| PU _D | DAC D Power-Up. When set, this bit places DAC D in normal operating mode. When cleared, this bit places DAC D in power-down mode (default). If the CLAMP ENABLE bit of the control register is cleared, DAC D will power down automatically on detection of an over-current, PU _D will be cleared to reflect this. |
| TSD | Thermal Shutdown Alert. Read-Only Bit. In the event of an overtemperature situation, this bit is set. |
| OC _A | DAC A Overcurrent Alert. Read-Only Bit. In the event of an overcurrent situation on DAC A, this bit is set. |
| OC _B | DAC B Overcurrent Alert. Read-Only Bit. In the event of an overcurrent situation on DAC B, this bit is set. |
| OC _C | DAC C Overcurrent Alert. Read-Only Bit. In the event of an overcurrent situation on DAC C, this bit is set. |
| OC _D | DAC D Overcurrent Alert. Read-Only Bit. In the event of an overcurrent situation on DAC D, this bit is set. |

FEATURES

ANALOG OUTPUT CONTROL

In many industrial process control applications, it is vital that the output voltage be controlled during power-up. When the supply voltages are changing during power-up, the V_{OUT} pins are clamped to 0 V via a low impedance path (approximately $4k\Omega$). To prevent the output amplifiers from being shorted to 0 V during this time, Transmission Gate G1 is also opened (see Figure 39). These conditions are maintained until the power supplies have stabilized and a valid word is written to a DAC register. At this time, G2 opens and G1 closes.

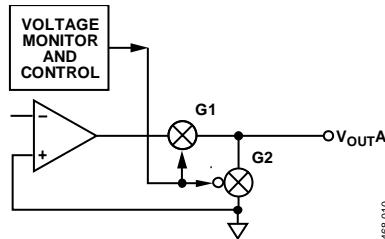

Figure 39. Analog Output Control Circuitry

OVERCURRENT PROTECTION

Each DAC channel of the AD5724/AD5734/AD5754 incorporates individual overcurrent protection. The user has two options for the configuration of the overcurrent protection, constant current clamp or automatic channel power-down. The configuration of the overcurrent protection is selected via the CLAMP ENABLE bit in the control register.

Constant Current Clamp (CLAMP ENABLE = 1)

If a short circuit occurs, in this configuration the current is clamped at 20 mA. This event is signaled to the user by the setting of the appropriate overcurrent (OC_x) bit in the power control register. Upon removal of the short-circuit fault, the OC_x bit is cleared.

Automatic Channel Power-Down (CLAMP ENABLE = 0)

If a short circuit occurs, in this configuration the shorted channel powers down and its output is clamped to ground via a resistance of approximately $4k\Omega$, also at this time the output of the amplifier is disconnected from the output pin. The short-circuit event is signaled to the user via the overcurrent (OC_x) bits, and the power-up (PU_x) bits also indicate which channels have been powered down. After the fault has been rectified, the channels can be powered up again by setting the PU_x bits.

THERMAL SHUTDOWN

The AD5724/AD5734/AD5754 incorporate a thermal shutdown feature that automatically shuts down the device if the core temperature exceeds approximately 150°C . The thermal shutdown feature is disabled by default and can be enabled via the TSD ENABLE bit of the control register. In the event of a thermal shutdown, the TSD bit of the power control register is set.

APPLICATIONS INFORMATION

+5V / ±5V OPERATION

When operating from a single +5V supply or a dual ±5V supply an output range of +5V or ±5V is not achievable as sufficient headroom for the output amplifier is not available. In this situation a reduced reference voltage can be used, for instance a 2V reference will produce an output range of +4V or ±4V, the 1V of headroom is more than enough for full operation. A standard value voltage reference of 2.048V can be used to produce output ranges of +4.096V and ±4.096V. Refer to the typical performance characteristics plots for performance data at a range of voltage reference values.

LAYOUT GUIDELINES

In any circuit where accuracy is important, careful consideration of the power supply and ground return layout helps to ensure the rated performance. The printed circuit board on which the AD5724/AD5734/AD5754 are mounted should be designed so that the analog and digital sections are separated and confined to certain areas of the board. If the AD5724/AD5734/AD5754 are in a system where multiple devices require an AGND-to-DGND connection, the connection should be made at one point only. The star ground point should be established as close as possible to the device.

The AD5724/AD5734/AD5754 should have ample supply bypassing of a 10 μF capacitor in parallel with a 0.1 μF capacitor on each supply located as close to the package as possible, ideally right up against the device. The 10 μF capacitors are the tantalum bead type. The 0.1 μF capacitor should have low effective series resistance (ESR) and low effective series inductance (ESI) such as the common ceramic types, which provide a low impedance path to ground at high frequencies to handle transient currents due to internal logic switching.

The power supply lines of the AD5724/AD5734/AD5754 should use as large a trace as possible to provide low impedance paths and reduce the effects of glitches on the power supply line. Fast switching signals such as clocks should be shielded with digital ground to avoid radiating noise to other parts of the board and should never be run near the reference inputs. A ground line routed between the SDIN and SCLK lines helps reduce crosstalk between them (this is not required on a multilayer board that has a separate ground plane, but separating the lines does help). It is essential to minimize noise on the REFIN line because it couples through to the DAC output.

Avoid crossover of digital and analog signals. Traces on opposite sides of the board should run at right angles to each other. This reduces the effects of feed through the board. A microstrip technique is by far the best, but not always possible with a double-sided board. In this technique, the component side of the board is dedicated to ground plane, while signal traces are placed on the solder side.

GALVANICALLY ISOLATED INTERFACE

In many process control applications, it is necessary to provide an isolation barrier between the controller and the unit being controlled to protect and isolate the controlling circuitry from any hazardous common-mode voltages that may occur. The *iCoupler*® family of products from Analog Devices provides voltage isolation in excess of 2.5 kV. The serial loading structure of the AD5724/AD5734/AD5754 make them ideal for isolated interfaces because the number of interface lines is kept to a minimum. Figure 40 shows a 4-channel isolated interface to the AD5724/AD5734/AD5754 using an ADuM1400. For further information, visit <http://www.analog.com/icouplers>.

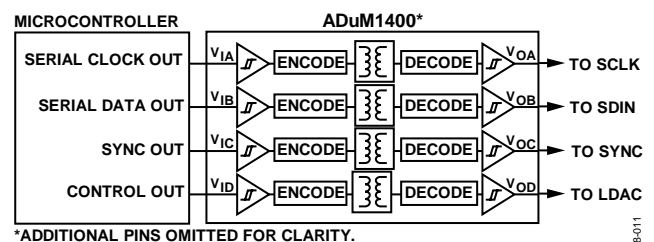

Figure 40. Isolated Interface

VOLTAGE REFERENCE SELECTION

To achieve optimum performance from the AD5724/AD5734/AD5754 over their full operating temperature range, a precision voltage reference must be used. Thought should be given to the selection of a precision voltage reference. The voltage applied to the reference inputs are used to provide a buffered positive and negative reference for the DAC cores. Therefore, any error in the voltage reference is reflected in the outputs of the device.

There are four possible sources of error to consider when choosing a voltage reference for high accuracy applications: initial accuracy, temperature coefficient of the output voltage, long term drift, and output voltage noise.

- Initial accuracy error on the output voltage of an external reference can lead to a full-scale error in the DAC. Therefore, to minimize these errors, a reference with low initial accuracy error specification is preferred. Choosing a reference with an output trim adjustment, such as the [ADR421](#), allows a system designer to trim out system errors by setting the reference voltage to a voltage other than the nominal. The trim adjustment can also be used at temperature to trim out any error.
- The temperature coefficient of a reference's output voltage affects INL, DNL, and TUE. A reference with a tight temperature coefficient specification should be chosen to reduce the dependence of the DAC output voltage on ambient conditions.
- Long term drift is a measure of how much the reference output voltage drifts over time. A reference with a tight

long-term drift specification ensures that the overall solution remains relatively stable over its entire lifetime.

- Reference output voltage noise needs to be considered in high accuracy applications that have relatively low noise budgets. It is important to choose a reference with as low an output noise voltage as practical for the required system

resolution. Precision voltage references such as the [ADR431](#) (XFET® design) produce low output noise in the 0.1 Hz to 10 Hz range. However, as the circuit bandwidth increases, filtering the output of the reference may be required to minimize the output noise.

Table 30. Some Precision References Recommended for Use with the AD5724/AD5734/AD5754

| Part No. | Initial Accuracy (mV max) | Long-Term Drift (ppm typ) | Temp Drift (ppm/°C max) | 0.1 Hz to 10 Hz Noise (µV p-p typ) |
|----------|---------------------------|---------------------------|-------------------------|------------------------------------|
| ADR431 | ±1 | 40 | 1 | 3.5 |
| ADR421 | ±1 | 50 | 1 | 1.75 |
| ADR03 | ±2.5 | 50 | 3 | 10 |
| ADR291 | ±2 | 50 | 3 | 8 |
| AD780 | ±1 | 20 | 10 | 4 |

MICROPROCESSOR INTERFACING

Microprocessor interfacing to the AD5724/AD5734/AD5754 is via a serial bus that uses standard protocol compatible with microcontrollers and DSP processors. The communications channel is a 3-wire (minimum) interface consisting of a clock signal, a data signal, and a synchronization signal. The AD5724/AD5734/AD5754 require a 24-bit data-word with data valid on the falling edge of SCLK.

For all interfaces, the DAC output update can be initiated automatically when all the data is clocked in, or it can be performed under the control of $\overline{\text{LDAC}}$. The contents of the registers can be read using the readback function.

AD5724/AD5734/AD5754 to Blackfin® DSP interface

Figure 41 shows how the AD5724/AD5734/AD5754 can be interfaced to Analog Devices Blackfin DSP. The Blackfin has an integrated SPI port that can be connected directly to the SPI pins of the AD5724/AD5734/AD5754 and the programmable I/O pins that can be used to set the state of a digital input such as the $\overline{\text{LDAC}}$ pin.

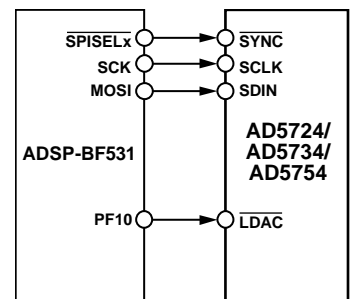
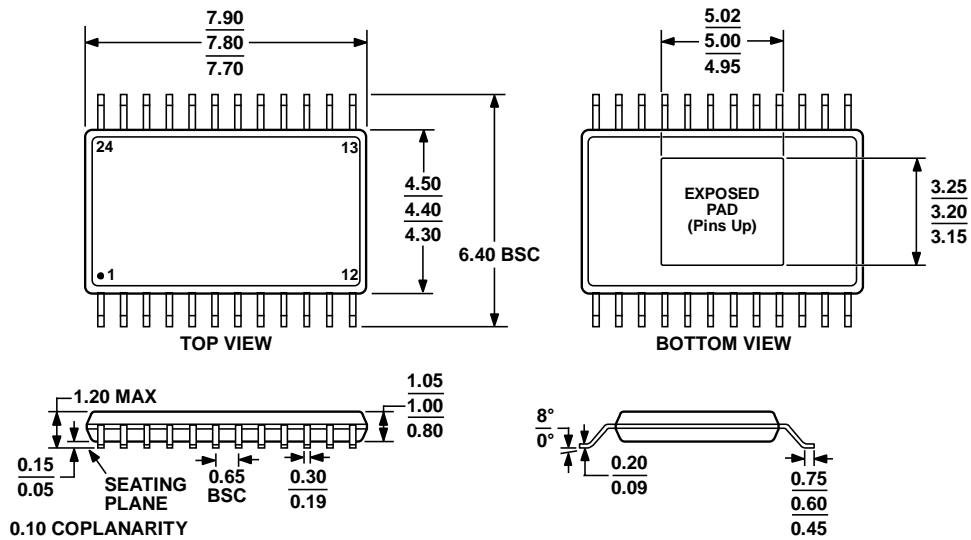

Figure 41. AD5724/AD5734/AD5754 to Blackfin Interface

OUTLINE DIMENSIONS



COMPLIANT TO JEDEC STANDARDS MO-153-ADT

Figure 42. 24-Lead Thin Shrink Small Outline Package, Exposed Pad [TSSOP_EP] (RE-24)

Dimensions shown in millimeters

050806-A

ORDERING GUIDE

| Model | Resolution | Temperature Range | INL | Package Description | Package Option |
|-------------------------------|------------|-------------------|---------|---------------------|----------------|
| AD5724BREZ ¹ | 12 | -40°C to 85°C | ±1 LSB | 24-Lead TSSOP_EP | RE-24 |
| AD5724BREZ-REEL7 ¹ | 12 | -40°C to 85°C | ±1 LSB | 24-Lead TSSOP_EP | RE-24 |
| AD5734BREZ ¹ | 14 | -40°C to 85°C | ±4 LSB | 24-Lead TSSOP_EP | RE-24 |
| AD5734BREZ-REEL7 ¹ | 14 | -40°C to 85°C | ±4 LSB | 24-Lead TSSOP_EP | RE-24 |
| AD5754BREZ ¹ | 16 | -40°C to 85°C | ±16 LSB | 24-Lead TSSOP_EP | RE-24 |
| AD5754BREZ-REEL7 ¹ | 16 | -40°C to 85°C | ±16 LSB | 24-Lead TSSOP_EP | RE-24 |

¹ Z = Pb-free part.

NOTES

NOTES